

Практикум из рачунарске анализе кола

5. Фреквенцијски домен

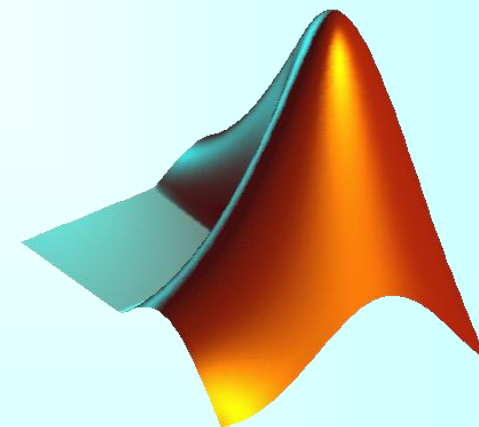
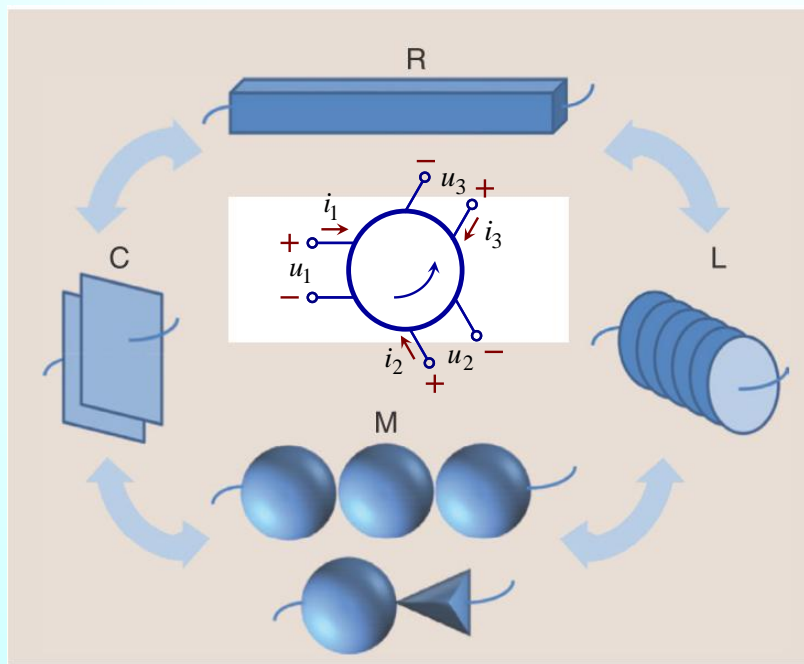

Милка Потребих Иваниш

Никола Баста

MATLAB: Simscape
Foundation Library
Utilities
Simulink

ОДРЕЂИВАЊЕ
АМПЛИТУДСКЕ & ФАЗНЕ
КАРАКТЕРИСТИКЕ

Филтар пропусник ниских учестаности

Вредности елемената електричног кола са слике су познате и постоји веза $L = R^2 C$.

(а) Одредити трансфер функцију (уопштену комплексну преносну функцију електричног

кола, трансмитансу напона) $\underline{H}(s) = \frac{U(s)}{U_g(s)}$.

(б) Нацртати амплитудску карактеристику.

(в) Одредити пропусни опсег 3 dB.

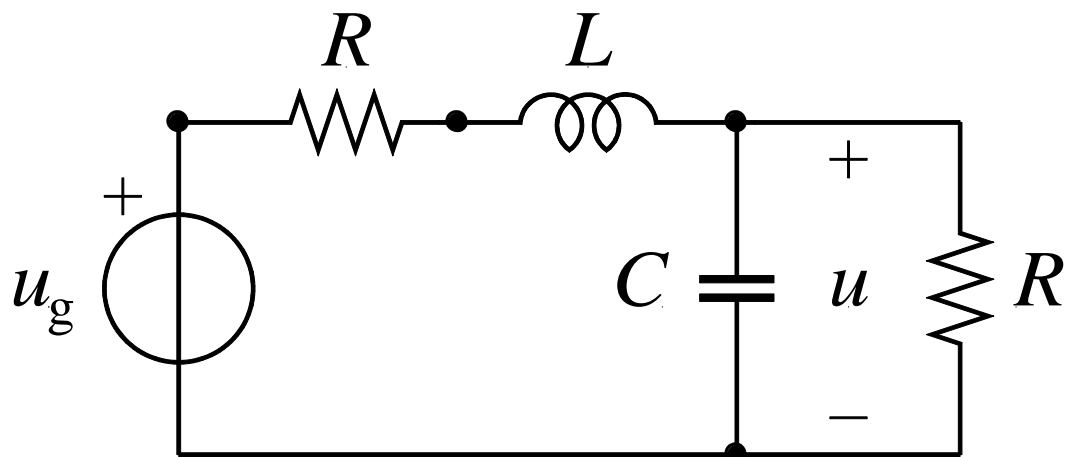

$$u_g = \sqrt{2}U_g \cos(\omega t + \theta_g)$$

Simulink, Simscape, Foundation Library, Utilities

$$R_1 = R_2 = 1\text{ k}\Omega$$

$$L = 1\text{ mH}$$

$$C = 1\text{ }\mu\text{F}$$

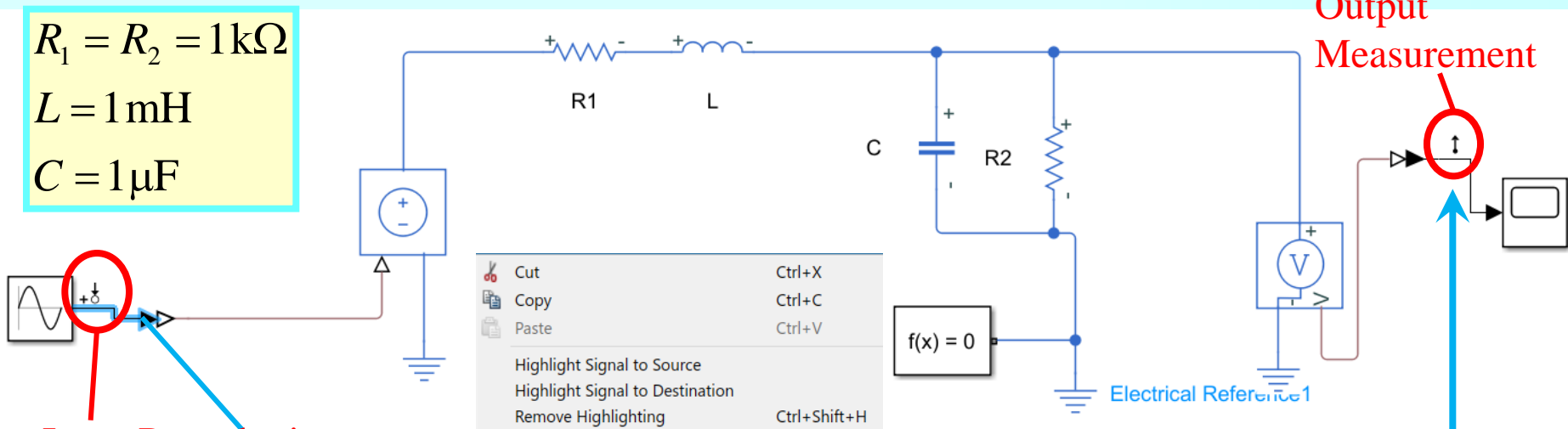

Input Perturbation

AC Voltage Source

$$u_g = \sqrt{2} \underbrace{U_g}_{230\text{ V}} \sin\left(\underbrace{\omega}_{2\pi f}_{50\text{ Hz}} t + \underbrace{\theta_g}_{\pi/2}\right)$$

- Cut Ctrl+X
- Copy Ctrl+C
- Paste Ctrl+V
- Highlight Signal to Source
- Highlight Signal to Destination
- Remove Highlighting Ctrl+Shift+H
- Arrange Automatically Ctrl+Shift+A
- Add Conditional Breakpoint
- Show Value Label of Selected Port
- Log Selected Signals
- Viewers & Generators Manager...
- Open Viewer
- Create & Connect Viewer
- Connect To Viewer
- Disconnect Viewer
- Delete Viewer
- Linear Analysis Points
- Signal Hierarchy
- Properties

- Linearization Manager...
- Open-loop Input
- Open-loop Output
- Loop Transfer
- Loop Break
- Input Perturbation
- Output Measurement
- Sensitivity
- Complementary Sensitivity
- Trim Output Constraint
- Help Me Select...

Output Measurement

Right click

Right click

Simulink: Apps -> Model Linearizer

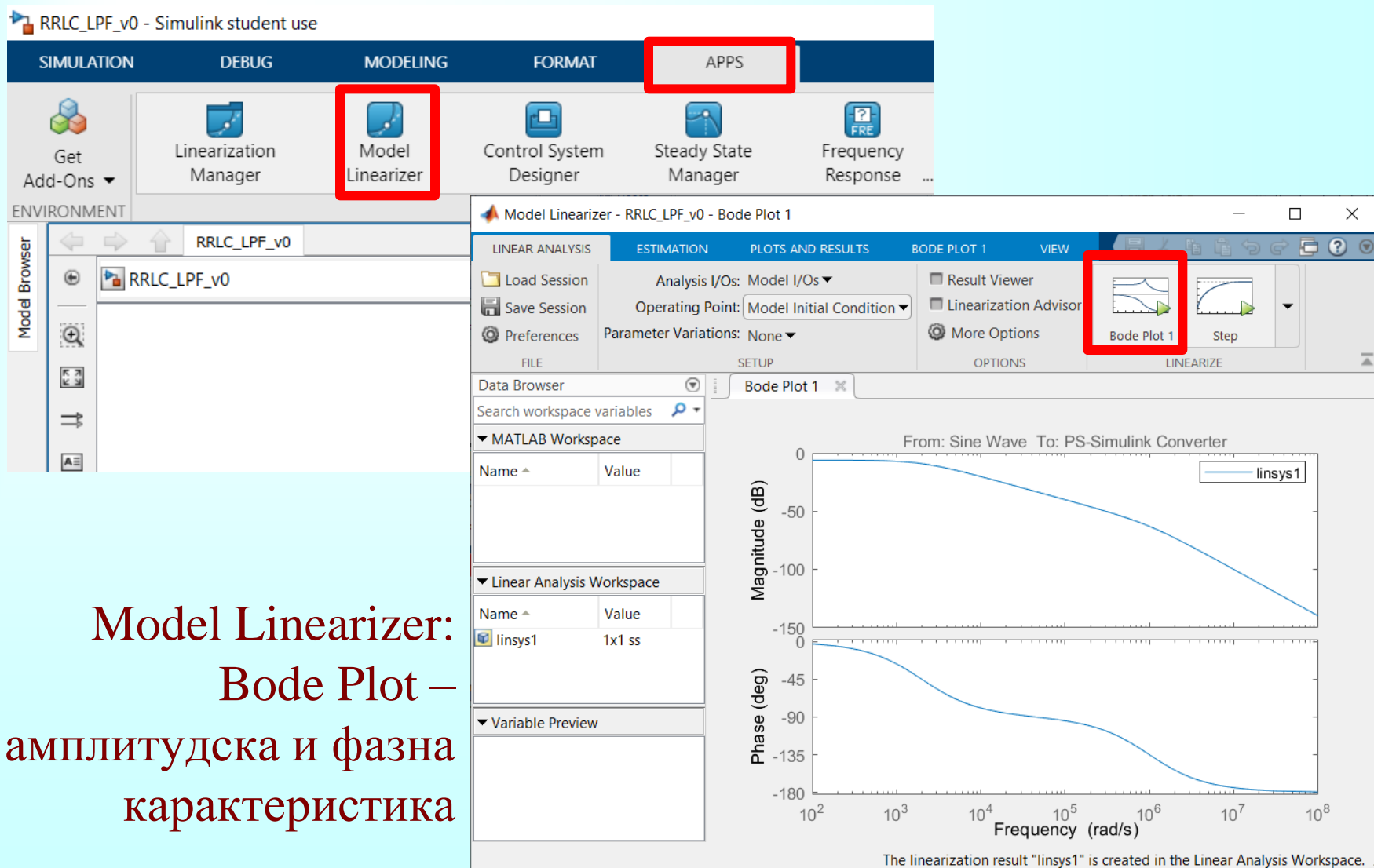

The screenshot displays the Simulink Model Linearizer interface. The 'APPS' tab is selected in the top menu bar, and the 'Model Linearizer' icon is highlighted. The main window shows the 'Bode Plot 1' window, which contains two plots: Magnitude (dB) and Phase (deg) versus Frequency (rad/s). The magnitude plot shows a roll-off from 0 dB at 10² rad/s to -150 dB at 10⁸ rad/s. The phase plot shows a phase shift from 0 degrees to -180 degrees over the same frequency range. The 'Bode Plot 1' icon in the toolbar is also highlighted.

Model Linearizer:
Bode Plot – амплитудска и фазна карактеристика

Name	Value
MATLAB Workspace	
Linear Analysis Workspace	
Name	Value
linsys1	1x1 ss
Variable Preview	

The linearization result "linsys1" is created in the Linear Analysis Workspace. ...

Одскочни одзив – Step Plot

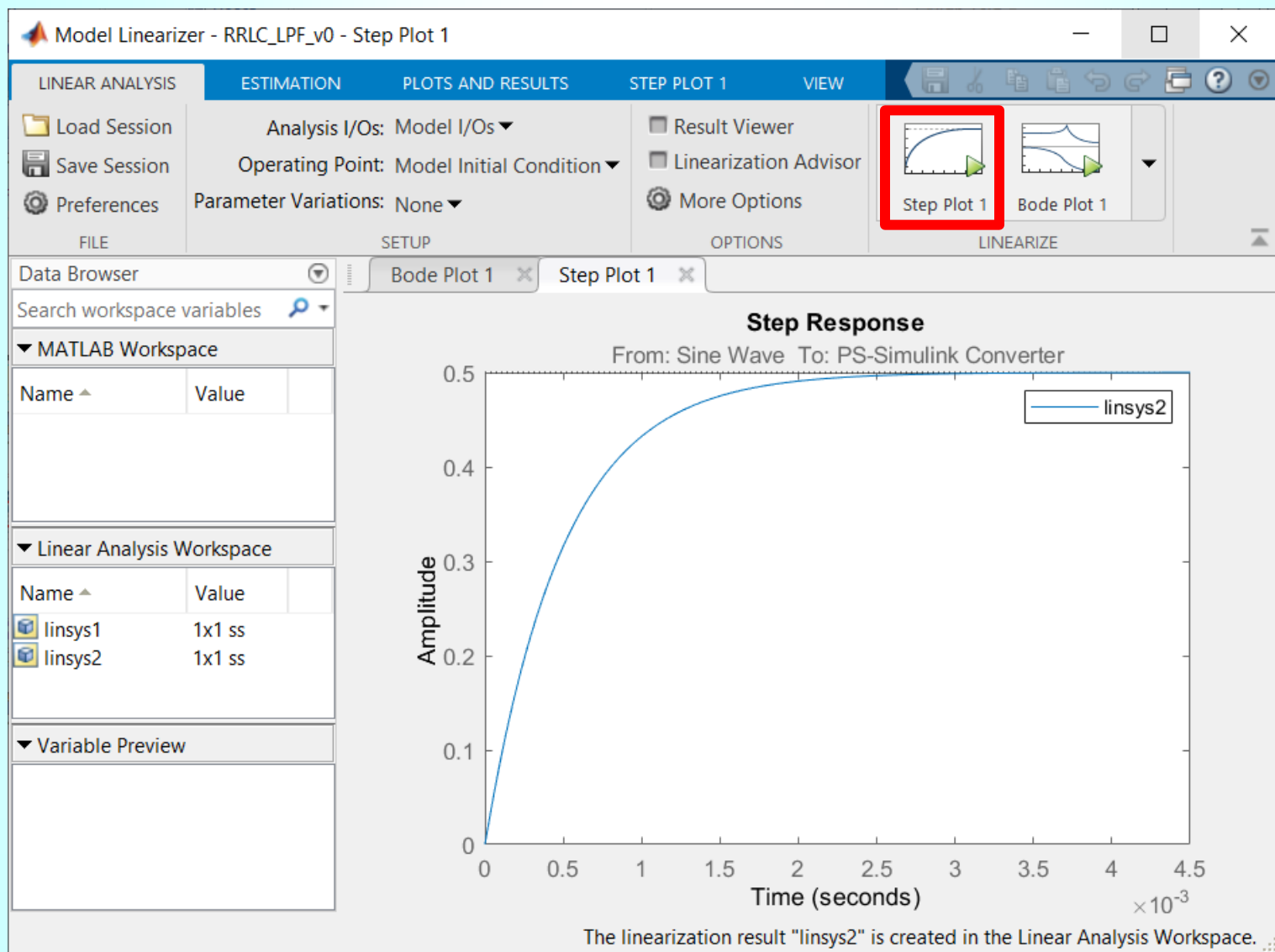

Импулсни одзив – Impulse Plot

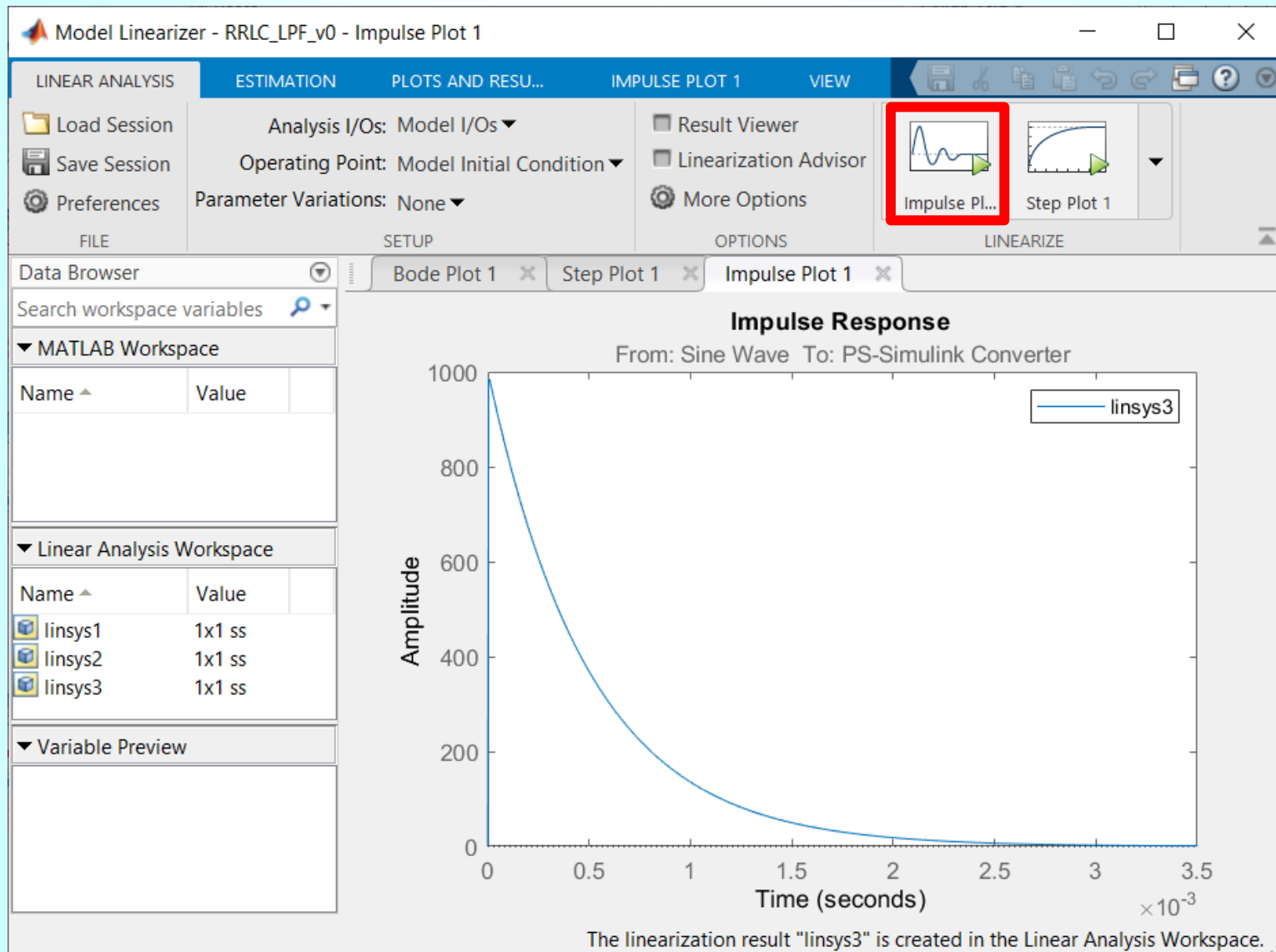

Полови и нуле трансфер функције – Pole Zero Plot

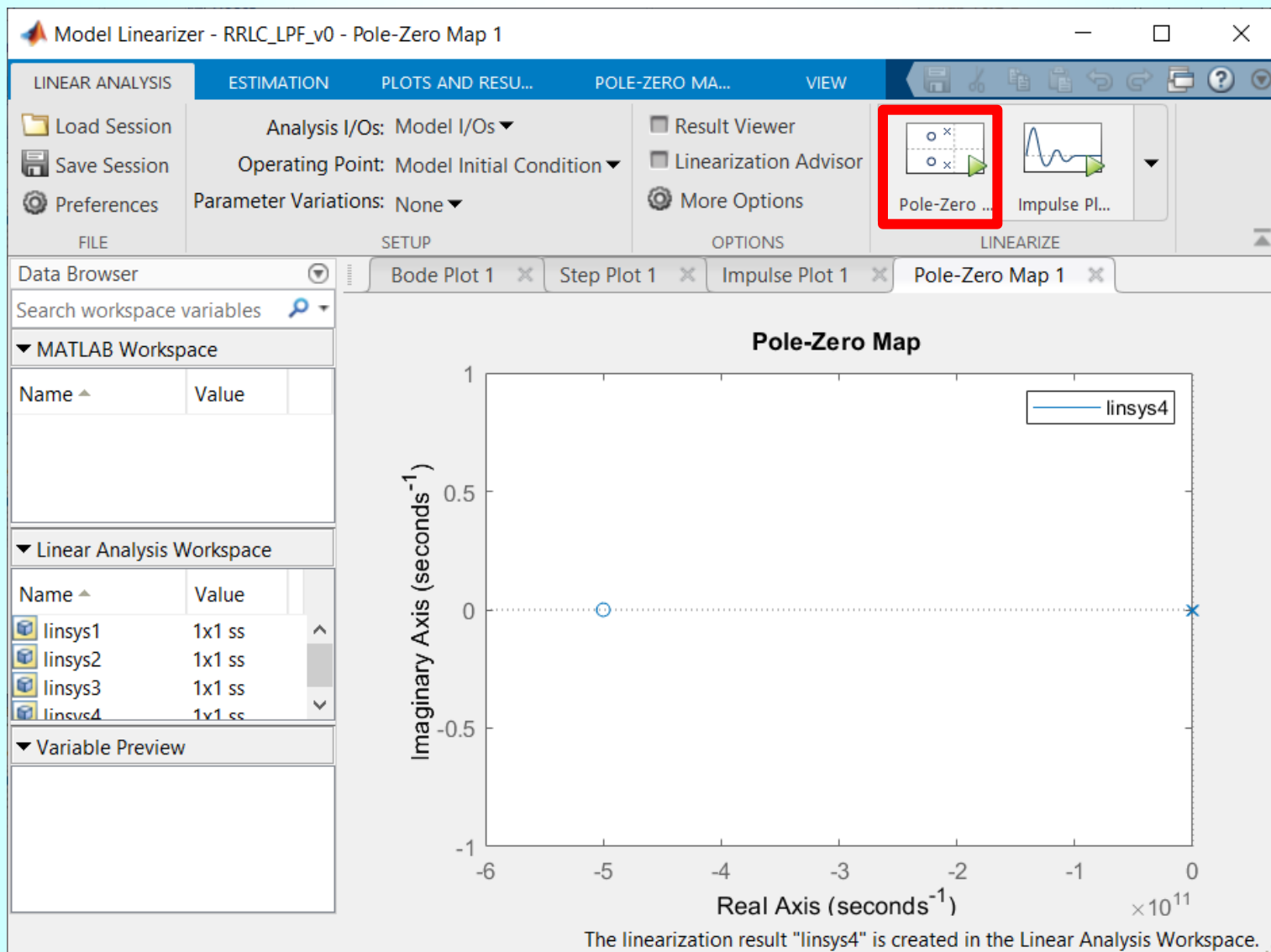

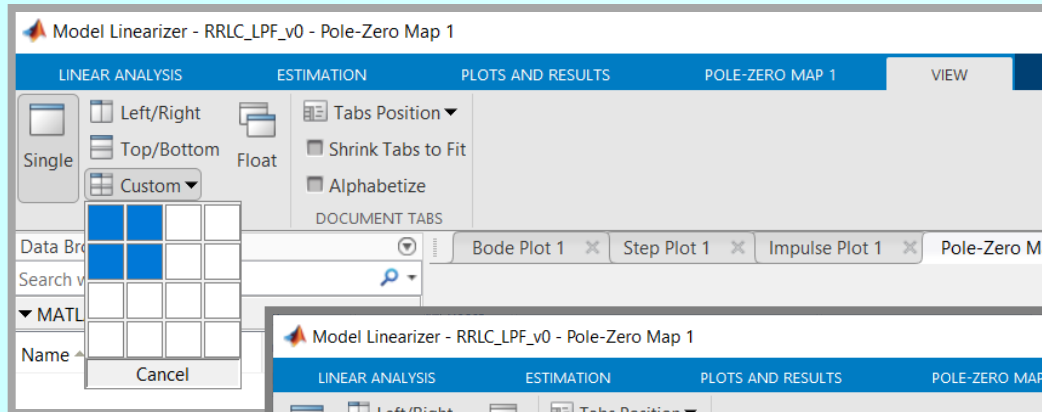

View > Custom > 2x2

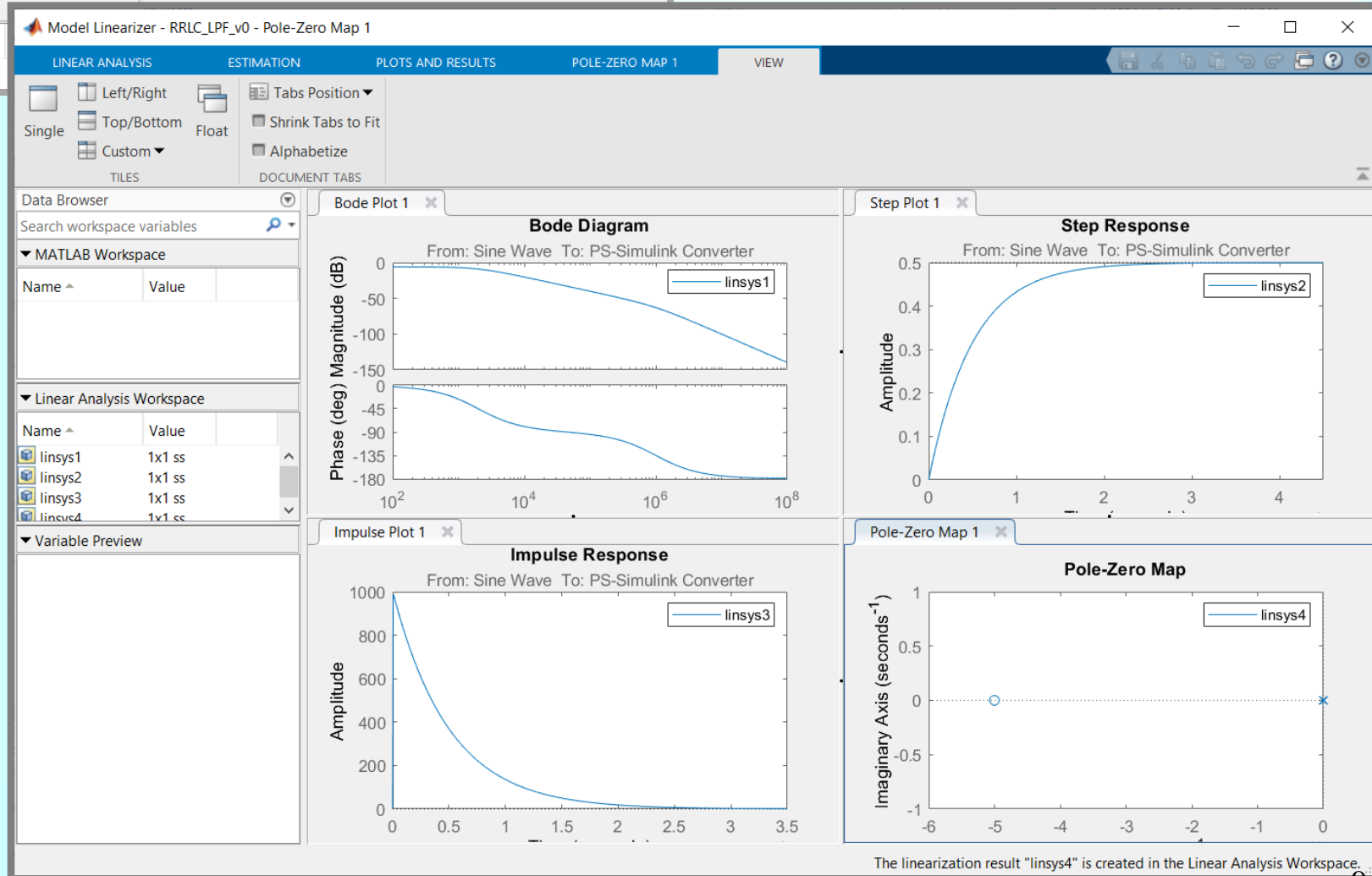

The linearization result "linsys4" is created in the Linear Analysis Workspace.

ФРЕКВЕНЦИЈСКИ ОДЗИВ

Оdređivanje uopštene kompleksne funkcije

```
clear variables
syms w C L R
assume(0 < R & 0 < C & 0 < L )
```

```
zamena = L == C*R^2
```

```
zamena = L = C R^2
```

```
vrednosti = [C == 1, R == 1]
```

```
vrednosti = (C = 1 R = 1)
```

```
syms s
Z1 = R + s*L
```

```
Z1 = R + L s
```

```
Z2 = 1/(s*C + 1/R)
```

```
Z2 =
1
C s + 1/R
```

```
syms H(s)
H(s) = subs(Z2/(Z1 + Z2), lhs(zamena), rhs(zamena))
```

```
H(s) =
1
(C s + 1/R) (R + 1/(C s + 1/R) + C R^2 s)
```

```
simplify(H(s))
```

```
ans =
1
C^2 R^2 s^2 + 2 C R s + 2
```

ТРАНСФЕР ФУНКЦИЈА

Amplitudska i fazna karakteristika

```
syms Hjw(w)
Hjw(w) = simplify(subs(H(s), s, 1i*w))
```

```
Hjw(w) =
-C^2 R^2 w^2 + 2 C R w i - 2
C^4 R^4 w^4 + 4
```

```
syms Aw(w)
Aw(w) = simplify(abs(Hjw(w)))
```

```
Aw(w) =
|C^2 R^2 w^2 + 2 C R w i - 2|
|C^4 R^4 w^4 + 4|
```

```
syms phi(w)
phi(w) = expand(angle(Hjw(w)))
```

```
phi(w) =
atan2(-2 C R w / (C^4 R^4 w^4 + 4), (2 - C^2 R^2 w^2) / (C^4 R^4 w^4 + 4))
```

АМПЛИТУДСКА И ФАЗНА КАРАКТЕРИСТИКА

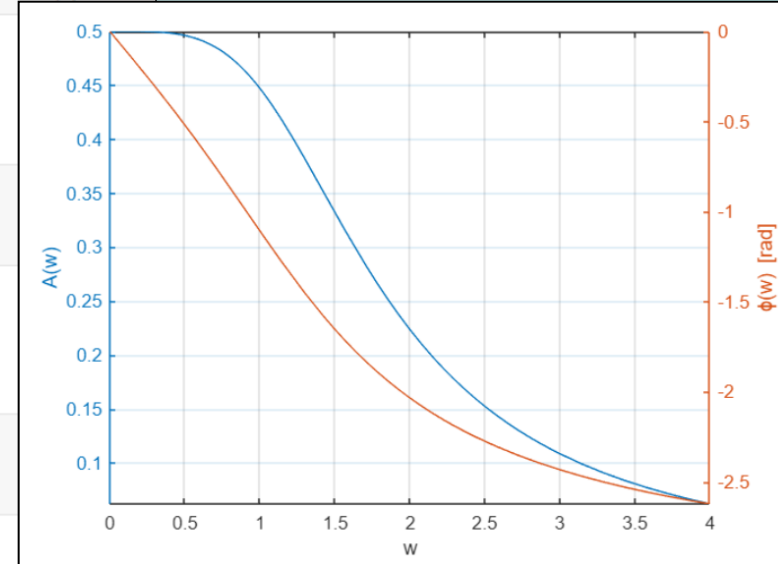

```
figure
yyaxis left
fplot(w, subs(Aw(w), lhs(vrednosti), rhs(vrednosti)), [0,4])
ylabel('A(w)')
yyaxis right
fplot(w, subs(phi(w), lhs(vrednosti), rhs(vrednosti)), [0,4])
ylabel('\phi(w) [rad]')
```

```
xlabel('w')
grid on
```

Одређивање пропусног опсега

$$A_{ref} = A_w(0)$$

$$A_{ref} =$$

$$\frac{1}{2}$$

$$\text{assume}(0 < w)$$

$$w_{3dB} = \text{solve}(A_w(w) == A_{ref}/\sqrt{2}, w)$$

$$w_{3dB} =$$

$$\frac{\sqrt{2}}{C R}$$

$$\text{BandPass3dB} = [0, w_{3dB}]$$

$$\text{BandPass3dB} =$$

$$\left(0 \quad \frac{\sqrt{2}}{C R}\right)$$

$$wg1 = \text{subs}(w_{3dB}(1), \text{lhs}(vrednosti), \text{rhs}(vrednosti))$$

$$wg1 = \sqrt{2}$$

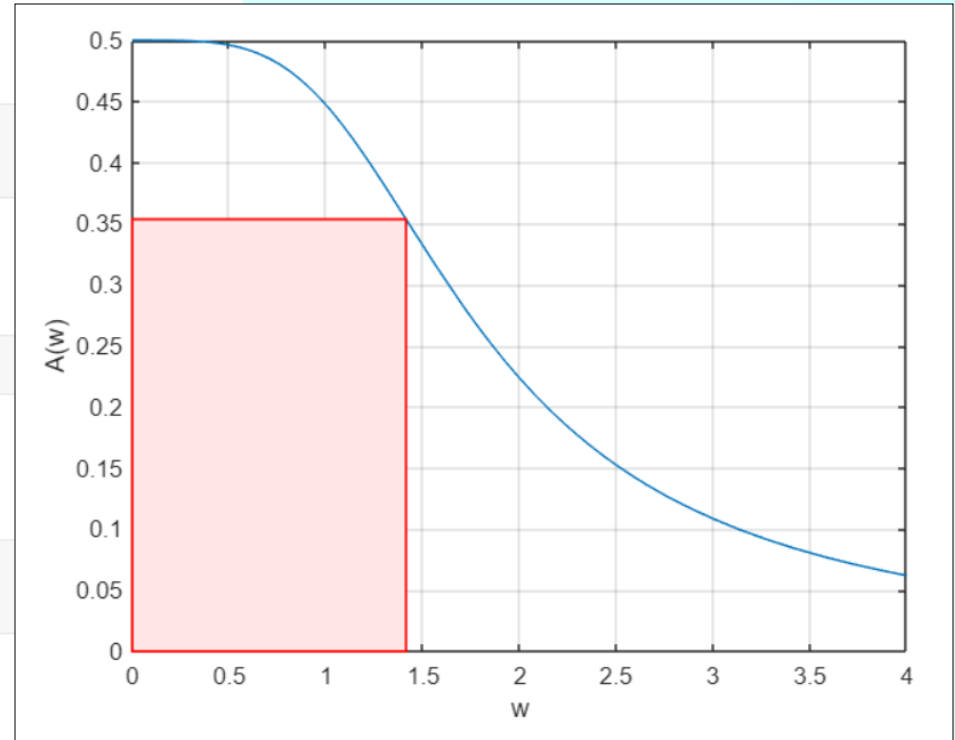

Означавање пропусног опсега у графику

```
figure
fplot(w, subs(Aw(w), lhs(vrednosti), rhs(vrednosti)), [0,4])
hold on
rectangle('Position',[0, 0, double(wg1), double(Aref/sqrt(2))],...
          'EdgeColor','r',...
          'FaceColor',[1 0.9 0.9],...
          'LineWidth',1)
hold off
ylabel('A(w)')
xlabel('w')
grid on
```

Филтар пропусник високих учестаности

Вредности елемената електричног кола са слике су познате и постоји веза $L = R^2 C$.

(а) Одредити трансфер функцију (уопштenu комплексну преносну функцију електричног кола, трансмитансу напона) $\underline{H}(s) = \frac{U(s)}{U_g(s)}$.

(б) Нацртати амплитудску карактеристику.

(в) Одредити пропусни опсег 3 dB.

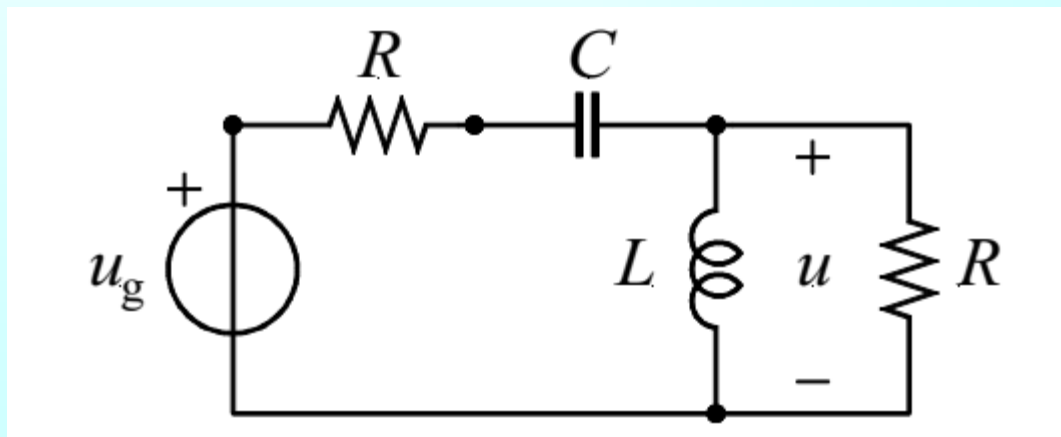

$$u_g = \sqrt{2}U_g \cos(\omega t + \theta_g)$$

Simulink, Simscape, Foundation Library, Utilities

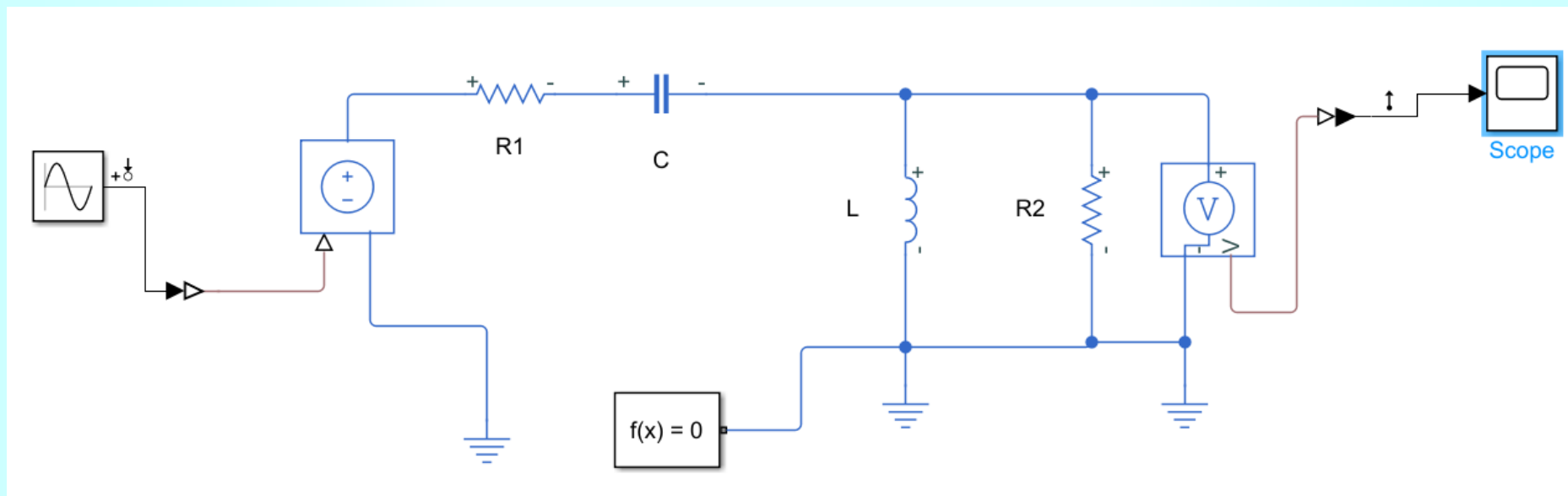

AC Voltage Source

$$u_g = \sqrt{2} \underbrace{U_g}_{230\text{ V}} \sin\left(\underbrace{\omega}_{2\pi f}_{50\text{ Hz}} t + \underbrace{\theta_g}_{\pi/2} \right)$$

$$R_1 = R_2 = 1\text{ k}\Omega$$

$$L = 1\text{ mH}$$

$$C = 1\text{ }\mu\text{F}$$

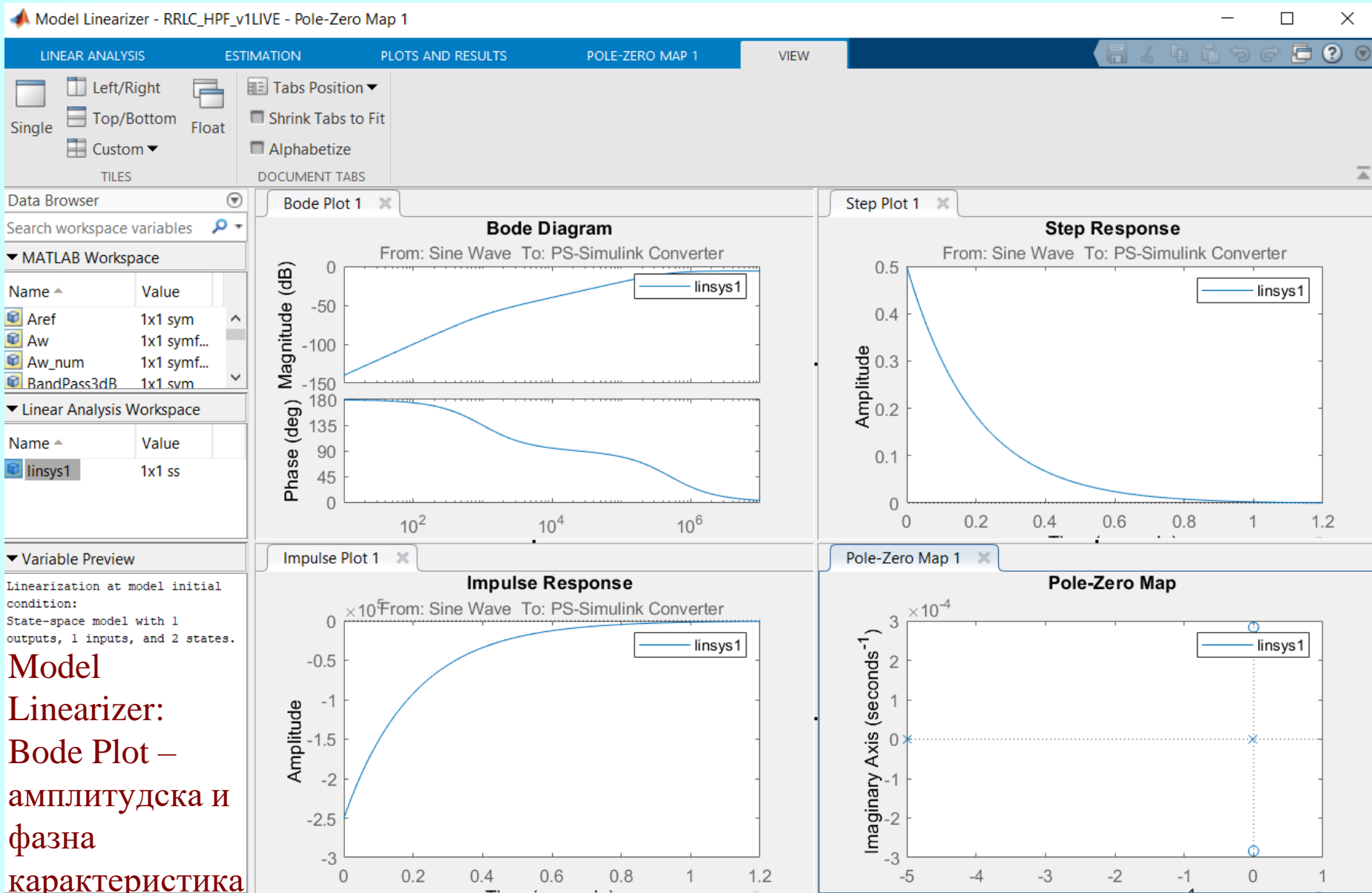

Model
Linearizer:
Bode Plot –
амплитудска и
фазна
карактеристика

The linearization result "linsys1" is created in the Linear Analysis Workspace. .

Određivanje uopštene kompleksne funkcije

```
clear variables
syms w C L R
assume(0 < R & 0 < C & 0 < L )
```

```
zamena = L == C*R^2
```

```
zamena = L = C R^2
```

```
vrednosti = [C == 1, R == 1]
```

```
vrednosti = (C = 1 R = 1)
```

```
syms s
Z1 = R + 1/(s*C)
```

```
Z1 =
R + 1/C s
```

```
Z2 = 1/(1/(s*L) + 1/R)
```

```
Z2 =
1
1/R + 1/L s
```

```
syms H(s)
H(s) = subs(Z2/(Z1 + Z2), lhs(zamena), rhs(zamena))
```

```
H(s) =
1
(1/R + 1/(C R^2 s)) (R + 1/C s + 1/(1/R + 1/(C R^2 s)))
```

```
simplify(H(s))
```

```
ans =
C^2 R^2 s^2
2 C^2 R^2 s^2 + 2 C R s + 1
```

Amplitudska i fazna karakteristika

```
syms Hjw(w)
Hjw(w) = subs(simplify(H(s)), s, 1i*w)
```

```
Hjw(w) =
C^2 R^2 w^2
-2 C^2 R^2 w^2 + 2 C R w i + 1
```

```
syms Aw(w)
Aw(w) = simplify(abs(Hjw(w)))
```

```
Aw(w) =
C^2 R^2 |w|^2
|-2 C^2 R^2 w^2 + 2 C R w i + 1|
```

```
syms phi(w)
phi(w) = expand(angle(Hjw(w)))
```

```
phi(w) =
angle(-w^2 / (-2 C^2 R^2 w^2 + 2 C R w i + 1))
```

MATLAB: Symbolic Toolbox

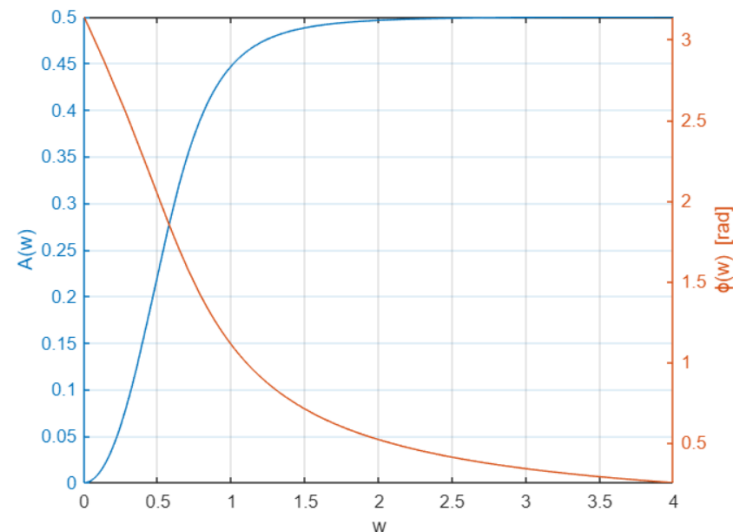

Crtaње amplitudske i fazne karakteristike

```
figure
yyaxis left
fplot(w, subs(Aw(w), lhs(vrednosti), rhs(vrednosti)), [0,4])
ylabel('A(w)')
yyaxis right
fplot(w, subs(phi(w), lhs(vrednosti), rhs(vrednosti)), [0,4])
ylabel('\phi(w) [rad]')
xlabel('w')
grid on
```

Одређивање пропусног опсега

```
Aref = limit(Aw(w), w, Inf)
```

```
Aref =  
1  
2
```

```
assume(0<w)  
w3dB = solve(Aw(w) == Aref/sqrt(2), w)
```

```
w3dB =  
sqrt(2)  
2 C R
```

```
BandPass3dB = [ w3dB, Inf]
```

```
BandPass3dB =  
(  
sqrt(2)  inf  
2 C R
```

```
wg1 = subs(w3dB(1), lhs(vrednosti), rhs(vrednosti))
```

```
wg1 =  
sqrt(2)  
2
```

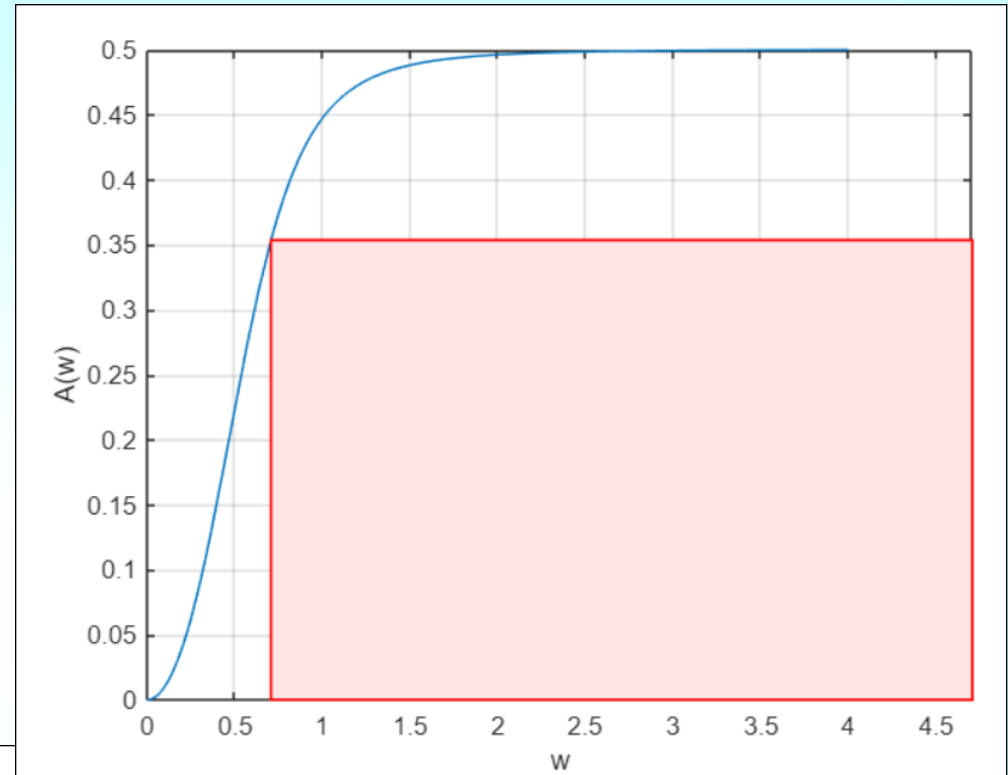

Означавање пропусног опсега у графiku

```
figure  
fplot(w, subs(Aw(w), lhs(vrednosti), rhs(vrednosti)), [0,4])  
hold on  
rectangle('Position',[double(wg1), 0, 4, double(Aref/sqrt(2)) ], ...  
          'EdgeColor','r',...  
          'FaceColor',[1 0.9 0.9],...  
          'LineWidth',1)  
  
hold off  
ylabel('A(w)')  
xlabel('w')  
grid on
```

Филтар пропусник опсега учестаности

Вредности елемената електричног кола са слике су познате и постоји веза $L = R^2 C$.

(а) Одредити трансфер функцију (уопштену комплексну преносну функцију електричног

кола, трансмитансу напона) $\underline{H}(s) = \frac{U(s)}{U_g(s)}$.

(б) Нацртати амплитудску карактеристику.

(в) Одредити пропусни опсег 3 dB.

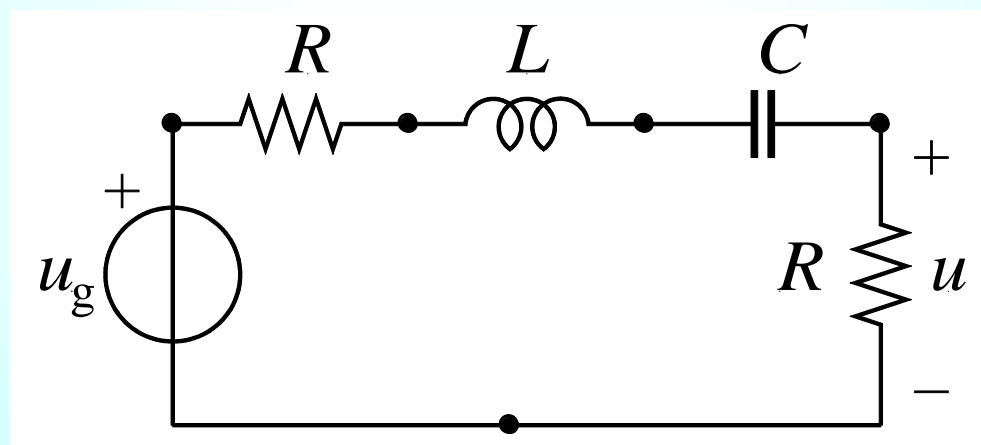

$$u_g = \sqrt{2}U_g \cos(\omega t + \theta_g)$$

Simulink Simscape Foundation Library Utilities

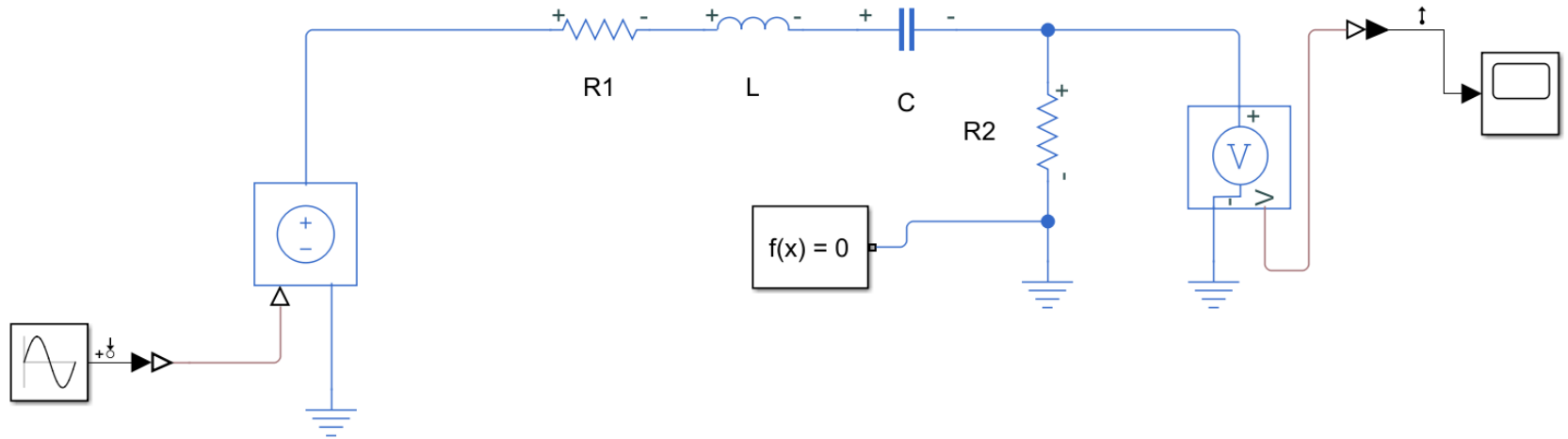

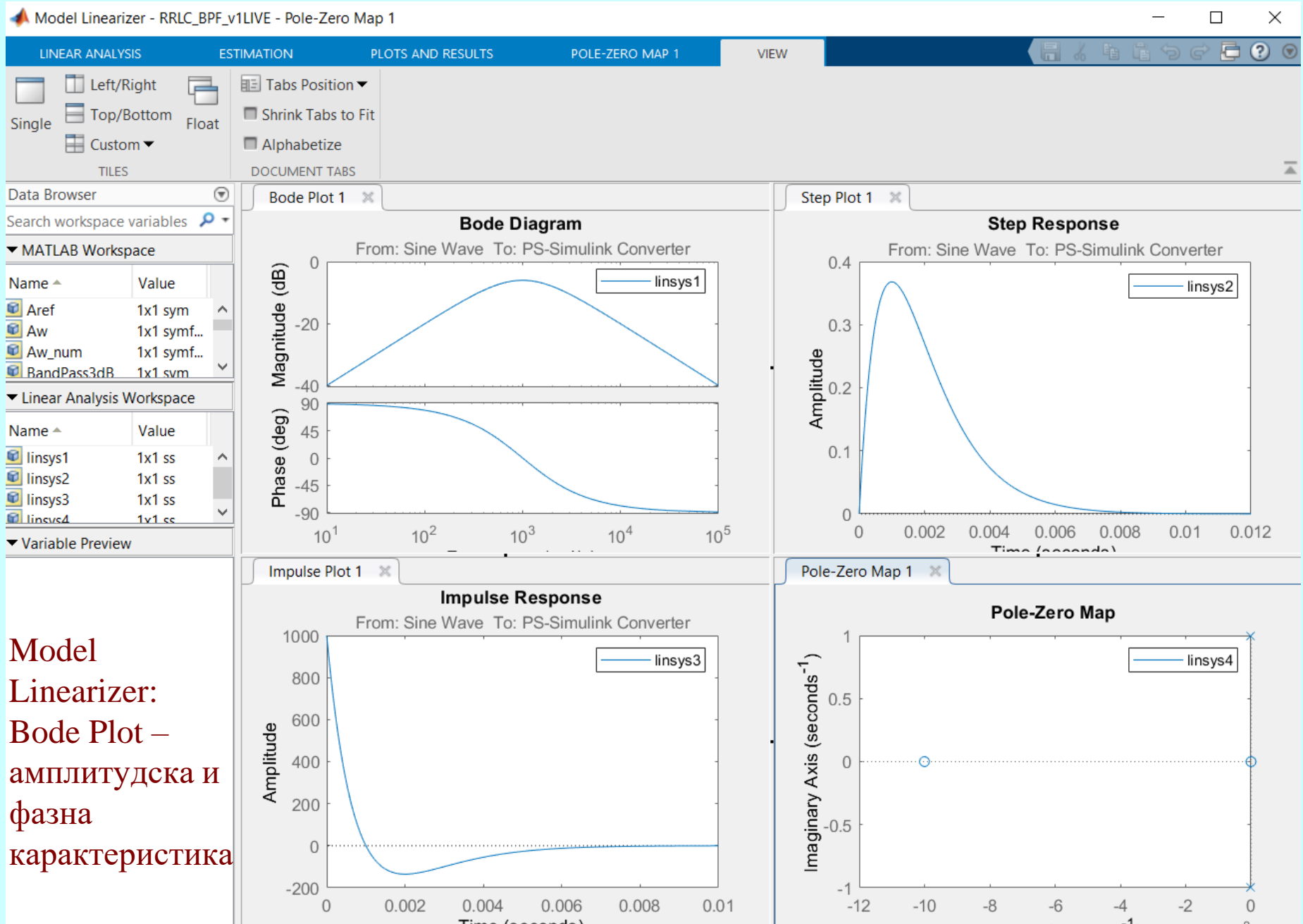

Model Linearizer:
Bode Plot – амплитудска и фазна карактеристика

Određivanje uopštene kompleksne funkcije

```
clear variables
syms w C L R
assume(0 < R & 0 < C & 0 < L )
```

MATLAB: Symbolic Toolbox

```
zamena = L == C*R^2
```

```
zamena = L = C R^2
```

```
vrednosti = [C == 1, R == 1]
```

```
vrednosti = (C = 1 R = 1)
```

```
syms s H(s)
H(s) = simplify(subs(R/(R + s*L + 1/(s*C) + R), lhs(zamena), rhs(zamena)))
```

$$H(s) = \frac{C R s}{(C R s + 1)^2}$$

Amplitudska i fazna karakteristika

```
syms Hjw(w)
Hjw(w) = simplify(subs(H(s), s, 1i*w))
```

$$Hjw(w) = \frac{C R w i}{(1 + C R w i)^2}$$

```
syms Aw(w)
assume(0 < w)
Aw(w) = simplify(abs(Hjw(w)))
```

$$Aw(w) = \frac{C R w}{|1 + C R w i|^2}$$

```
syms phi(w)
phi(w) = angle(Hjw(w))
```

$$\phi(w) = \text{angle}\left(\frac{w i}{(1 + C R w i)^2}\right)$$

Crtanje amplitudske i fазne karakteristike

```
figure
```

```
yyaxis left
fplot(w, subs(Aw(w), lhs(vrednosti), rhs(vrednosti)), [0,4])
ylabel('A(w)')
```

```
yyaxis right
fplot(w, subs(phi(w), lhs(vrednosti), rhs(vrednosti)), [0,4])
ylabel('\phi(w) [rad]')
xlabel('w')
grid on
```

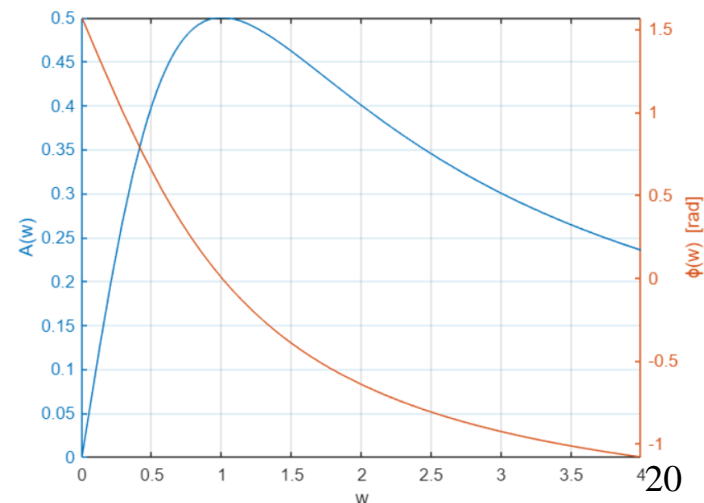

Одређивање пропусног опсега

```
syms Aw_num(w)
assume(0 < w)
Aw_num(w) = subs(Aw, lhs(vrednosti), rhs(vrednosti))
```

$$Aw_num(w) = \frac{w}{w^2 + 1}$$

```
wg = solve(diff(Aw_num,w) == sym(0), w, 'Real', true)
```

$$wg = 1$$

```
Aref = subs(Aw_num(wg))
```

$$Aref = \frac{1}{2}$$

```
w3dB = simplify(solve(Aw(w) == Aref/sqrt(2)))
```

$$w3dB = \left(\frac{\sqrt{2}-1}{CR}, \frac{\sqrt{2}+1}{CR} \right)$$

```
BandPass3dB = w3dB.'
```

$$BandPass3dB = \left(\frac{\sqrt{2}-1}{CR}, \frac{\sqrt{2}+1}{CR} \right)$$

```
wg1 = subs(w3dB(1), lhs(vrednosti), rhs(vrednosti))
```

$$wg1 = \sqrt{2} - 1$$

```
wg2 = subs(w3dB(2), lhs(vrednosti), rhs(vrednosti))
```

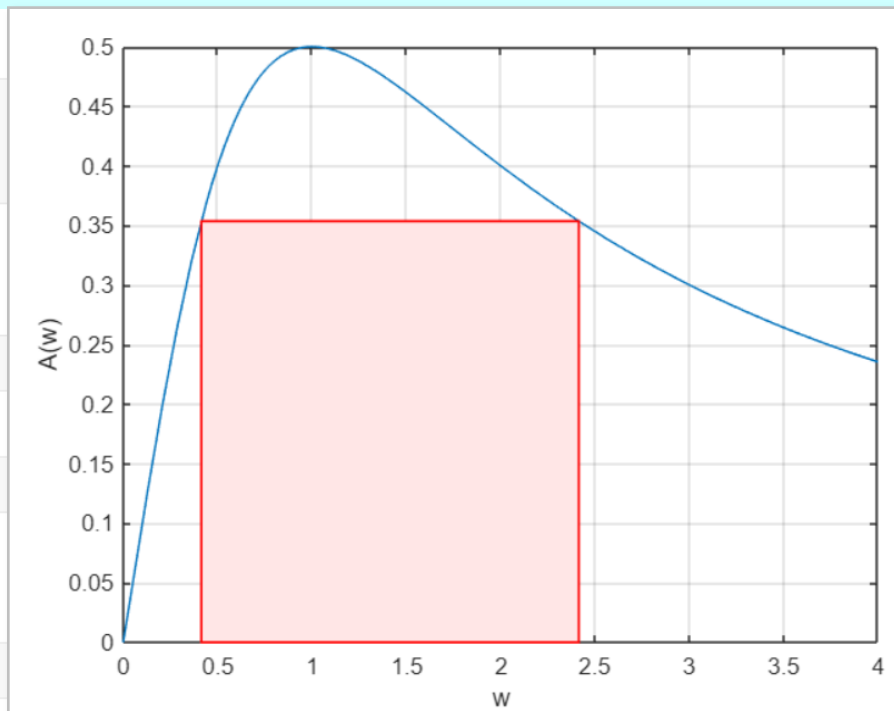

Означавање пропусног опсега у графiku

```
figure
fplot(w, subs(Aw(w), lhs(vrednosti), rhs(vrednosti)), [0,4])
hold on
rectangle('Position',[double(wg1), 0, double(wg2-wg1), double(Aref/sqrt(2))],...
          'EdgeColor','r',...
          'FaceColor',[1 0.9 0.9],...
          'Linewidth',1)
hold off
ylabel('A(w)')
xlabel('w')
grid on
```

Филтар непропусник опсега учестаности

Вредности елемената електричног кола са слике су познате и постоји веза $L = R^2 C$.

(а) Одредити трансфер функцију (уопштену комплексну преносну функцију електричног кола, трансмитансу напона) $\underline{H}(s) = \frac{\underline{U}(s)}{\underline{U}_g(s)}$.

(б) Нацртати амплитудску карактеристику.

(в) Одредити пропусни опсег 3 dB.

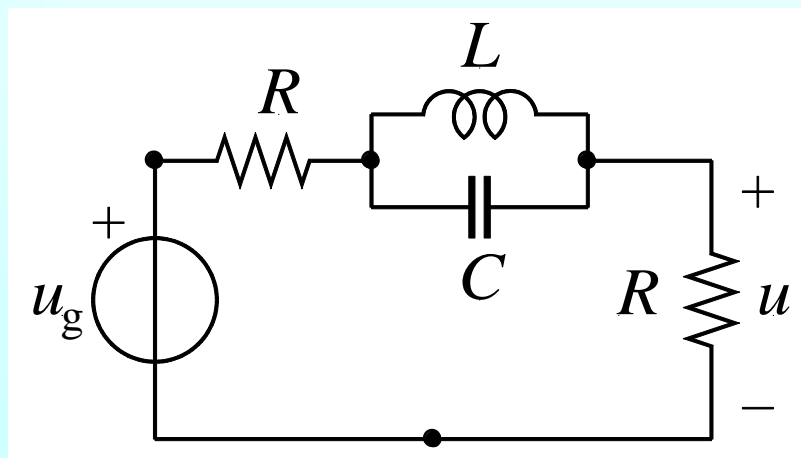

$$u_g = \sqrt{2}U_g \cos(\omega t + \theta_g)$$

Simulink Simscape Foundation Library Utilities

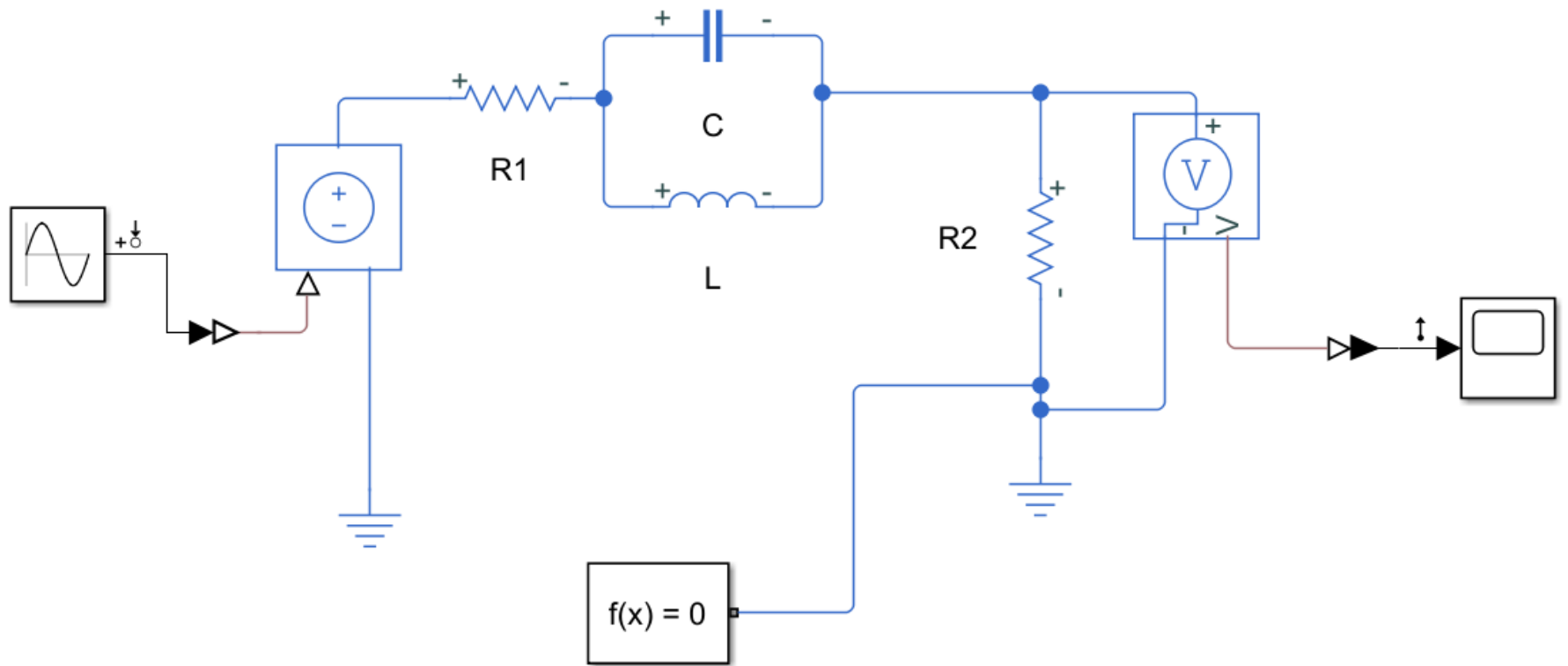

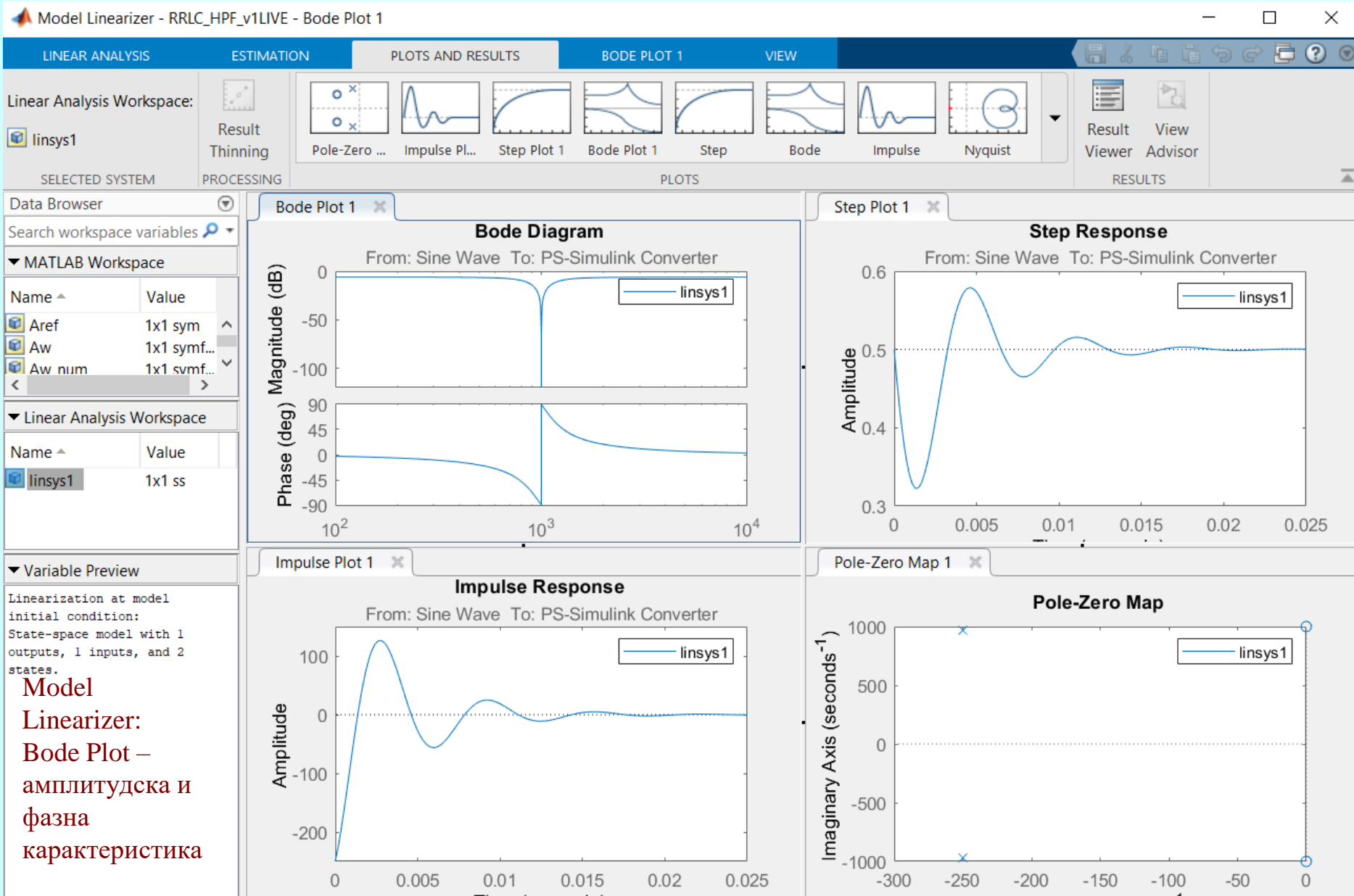

Model
Linearizer:
Bode Plot –
амплитудска и
фазна
карактеристика

Određivanje uopštene kompleksne funkcije

```
clear variables
syms w C L R
assume(0 < R & 0 < C & 0 < L )
```

```
zamena = L == C*R^2
```

```
zamena = L = C R^2
```

```
vrednosti = [C == 1, R == 1]
```

```
vrednosti = (C = 1 R = 1)
```

```
syms s H(s)
H(s) = simplify(subs(R/(R + 1/(1/(s*L) + s*C) + R), lhs(zamena), rhs(zamen
```

$$H(s) = \frac{C^2 R^2 s^2 + 1}{2 C^2 R^2 s^2 + C R s + 2}$$

MATLAB: Symbolic Toolbox

Amplitudska i fazna karakteristika

```
syms Hjw(w)
Hjw(w) = simplify(subs(H(s), s, 1i*w))
```

$$Hjw(w) = -\frac{C^2 R^2 w^2 - 1}{-2 C^2 R^2 w^2 + C R w i + 2}$$

```
syms Aw(w)
assume(0 < w)
Aw(w) = simplify(abs(Hjw(w)))
```

$$Aw(w) = \frac{|C^2 R^2 w^2 - 1|}{|-2 C^2 R^2 w^2 + C R w i + 2|}$$

```
syms phi(w)
phi(w) = angle(Hjw(w))
```

$$\phi(w) = \text{angle}\left(-\frac{C^2 R^2 w^2 - 1}{-2 C^2 R^2 w^2 + C R w i + 2}\right)$$

Crtanje amplitudske i fазne karakteristike

```
figure
yyaxis left
fplot(w, subs(Aw(w), lhs(vrednosti), rhs(vrednosti)), [0,4])
ylabel('A(w)')

yyaxis right
fplot(w, subs(phi(w), lhs(vrednosti), rhs(vrednosti)), [0,4])
ylabel('\phi(w) [rad]')
xlabel('w')
grid on
```

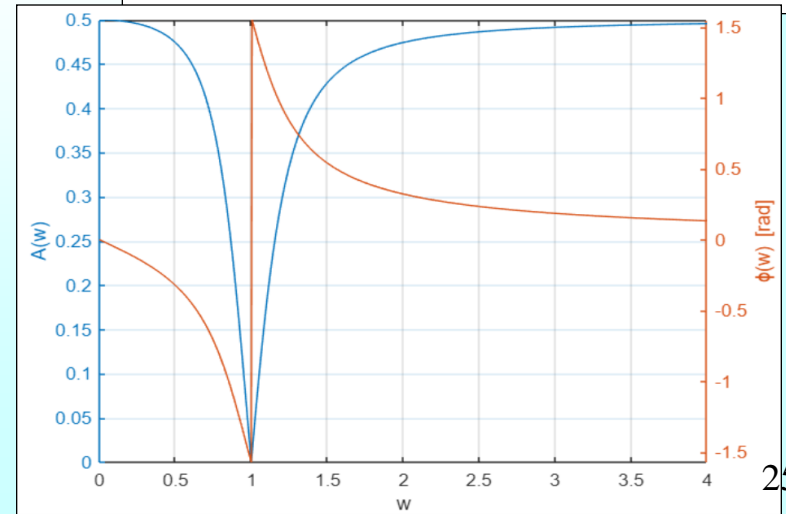

Одређивање пропусног опсега

```
syms Aw_num(w)
Aref = Aw(0)
```

```
Aref =
1/2
```

```
assume(w>0)
w3dB = expand(solve(Aw(w) == Aref/sqrt(2), w))
```

```
w3dB =
(
sqrt(9 - sqrt(17)) / (2 * C * R)
sqrt(sqrt(17) + 9) / (2 * C * R)
)
```

```
Aw_num(w) = subs(Aw, lhs(vrednosti), rhs(vrednosti))
```

```
Aw_num(w) =
|w^2 - 1| / sqrt(w^2 + (2 * w^2 - 2)^2)
```

```
wg1 = subs(w3dB(1), lhs(vrednosti), rhs(vrednosti))
```

```
wg1 =
sqrt(9 - sqrt(17)) / 2
```

```
wg2 = subs(w3dB(2), lhs(vrednosti), rhs(vrednosti))
```

```
wg2 =
sqrt(sqrt(17) + 9) / 2
```

Означавање пропусног опсега у графика

```
figure
fplot(w, subs(Aw(w), lhs(vrednosti), rhs(vrednosti)), [0,4])
hold on
rectangle('Position',[0, 0, double(wg1), double(Aref/sqrt(2))],...
'EdgeColor','r',...
'FaceColor',[1 0.9 0.9],...
'LineWidth',1)
rectangle('Position',[double(wg2), 0, double(4-wg2), double(Aref/sqrt(2))],...
'EdgeColor','r',...
'FaceColor',[1 0.9 0.9],...
'LineWidth',1)
hold off
ylabel('A(w)')
xlabel('w')
grid on
```

MATLAB: Symbolic Toolbox

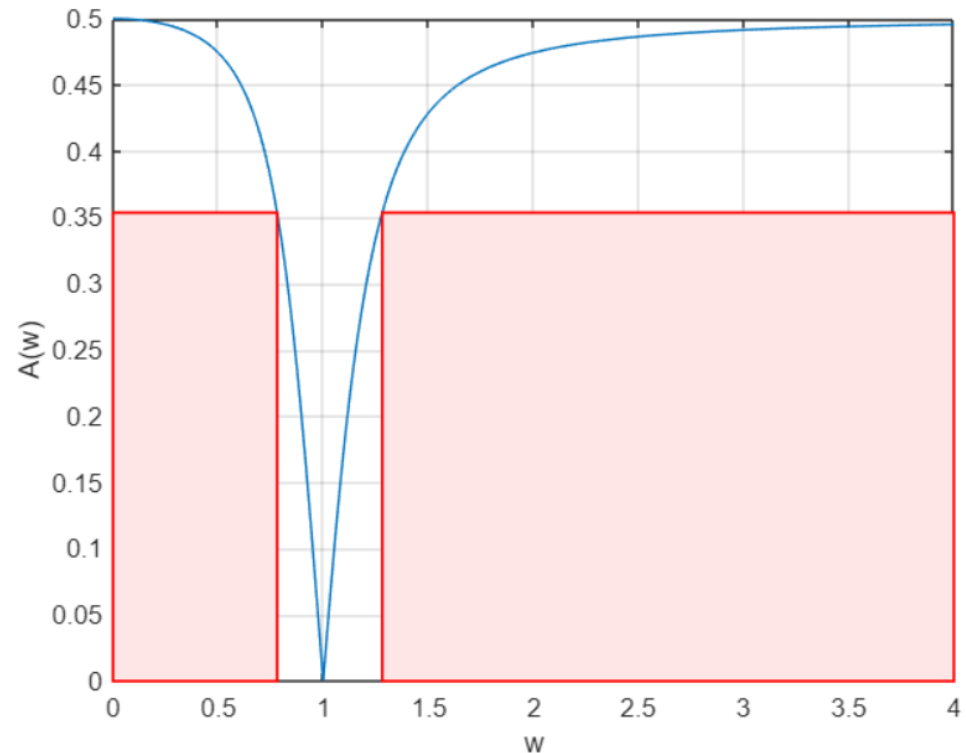

Устаљен сложенепериодичан одзив

Електрично коло са слике има познате вредности елемената:

$$L_1 = L, L_2 = 2L,$$

$$C_1 = C, C_2 = 2C,$$

$$R_1 = R_2 = R.$$

Побуда (екситација) је $i_g(t) = I_m + I_m \cos\left(\frac{1}{2\sqrt{CL}}t\right) + I_m \sin\left(\frac{1}{\sqrt{CL}}t\right)$

Одзив је устаљен.

(а) Одредити напон отпорника R_2 .

(б) Одредити напон струјног извора (струјног генератора).

(б) Ког реда је ово коло?

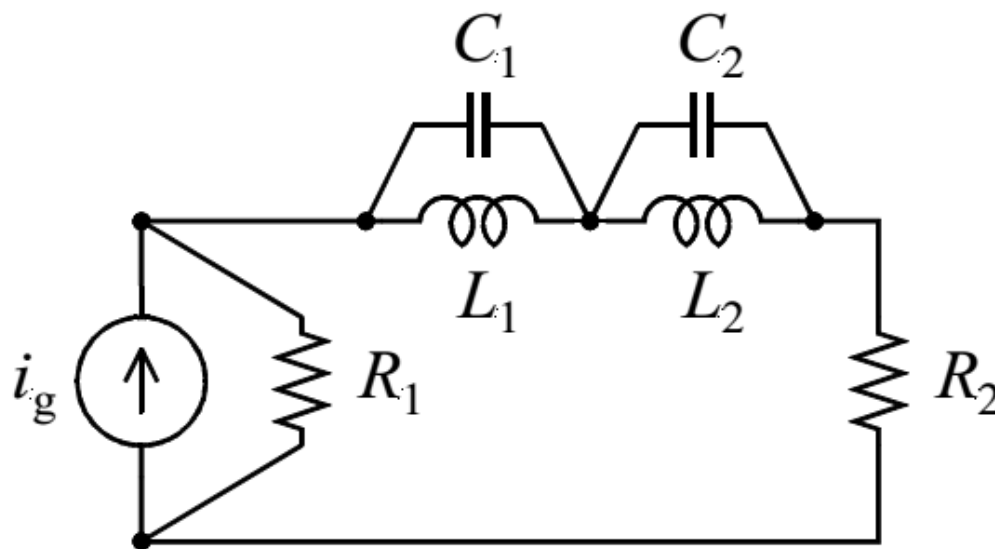

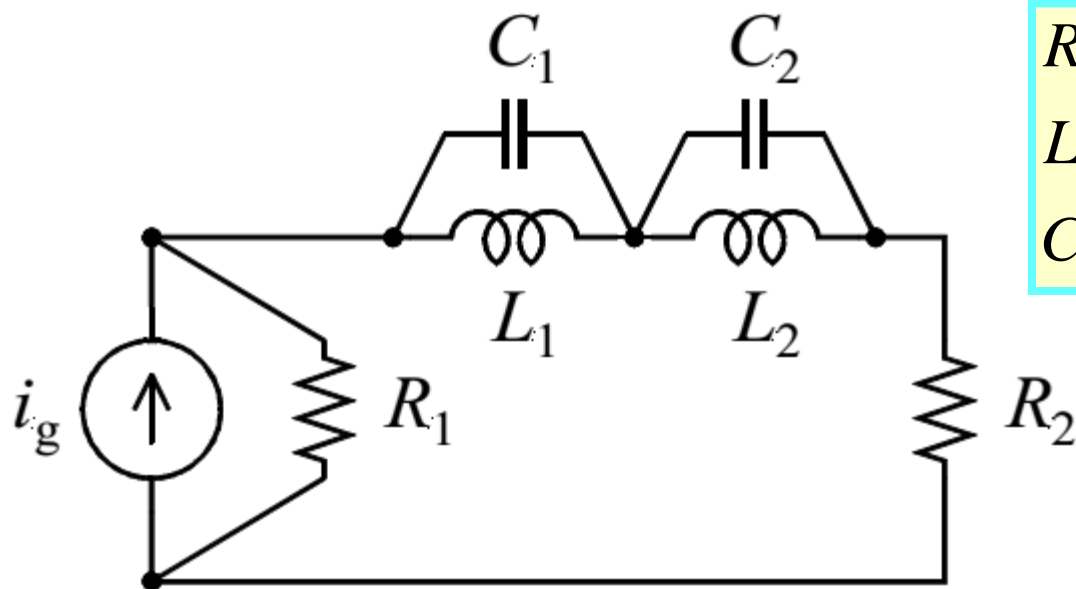

$$R_1 = R_2 = 1\text{k}\Omega$$

$$L_1 = L, L_2 = 2L, L = 0.5\text{ mH}$$

$$C_1 = C, C_2 = 2C, C = 5\mu\text{F}$$

$$i_g(t) = \underbrace{I_m}_{1\text{A}} + I_m \cos(\omega_1 t) + I_m \sin(\omega_2 t)$$

$$\omega_1 = \frac{1}{\sqrt{L_2 C_2}} = \frac{1}{2\sqrt{LC}} = 10^4 \text{ rad/s}$$

$$\omega_2 = \frac{1}{\sqrt{L_1 C_1}} = \frac{1}{\sqrt{LC}} = 2 \cdot 10^4 \text{ rad/s}$$

Simulink Simscape > Foundation Library, Utilities

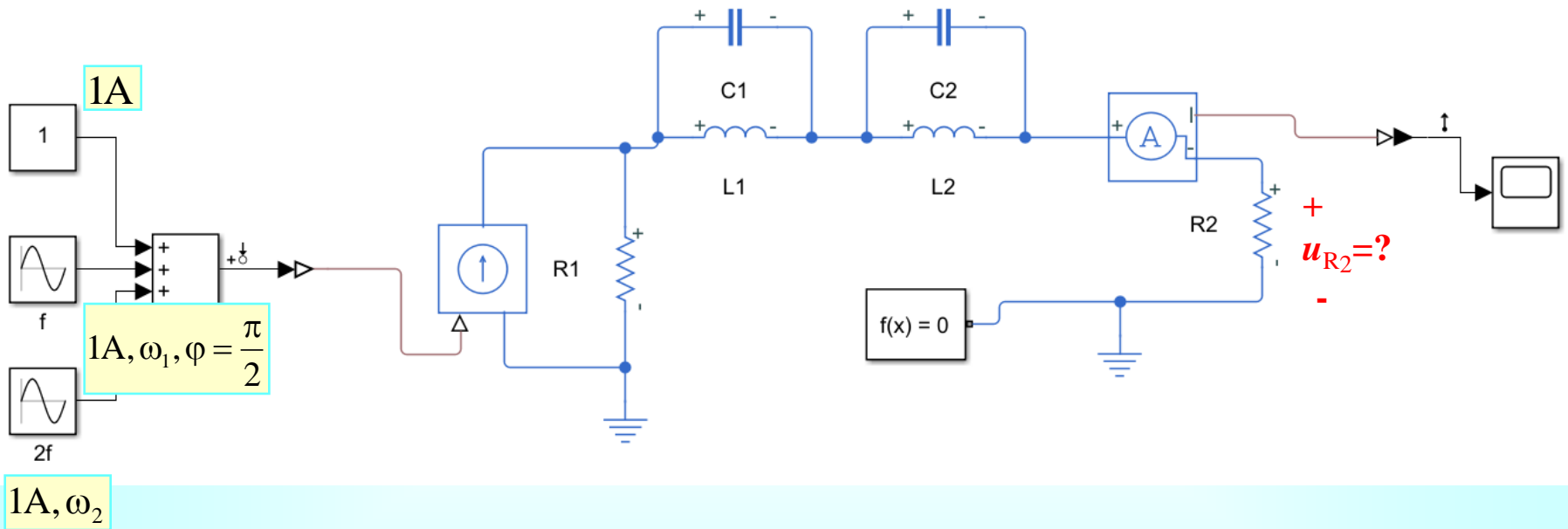

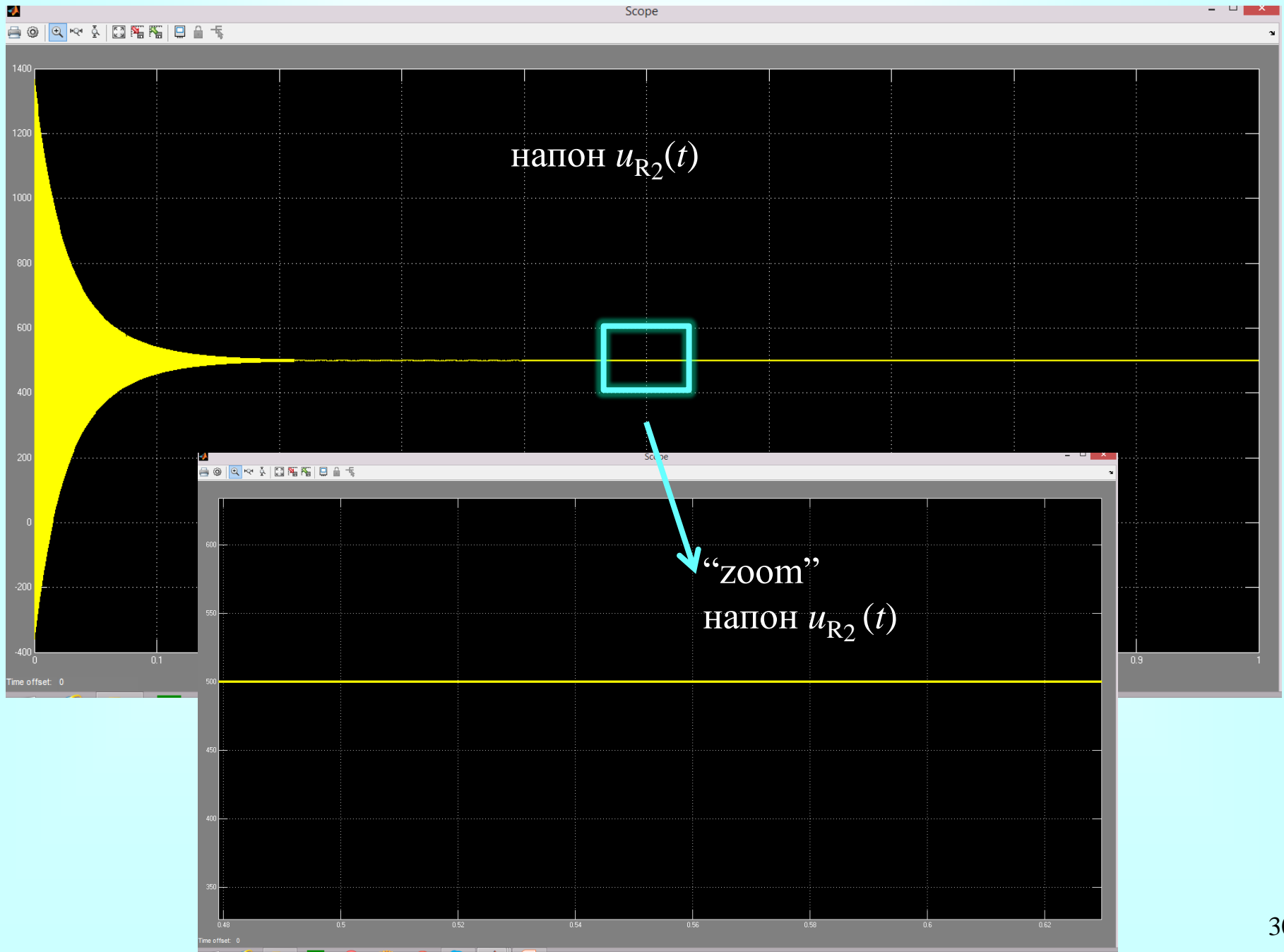

```
clear variables
close all

syms C C1 C2 I_m L L1 L2 R R1 R2
assume(0 < L1 & 0 < L2 & 0 < C1 & 0 < C2 & 0 < R1 & 0 < R2 & 0 < L & 0 < C & 0 < R & 0 < I_m)
```

Frekvencije, pobude, zamene

```
zamene = [L1 == L, C1 == C, L2 == 2 * L, C2 == 2*C, R1 == R, R2 == R]
```

```
zamene = (L1 = L C1 = C L2 = 2L C2 = 2C R1 = R R2 = R)
```

```
syms w0 w1 w2 I_g0 I_g1 I_g2
```

```
pobuda = [I_g0 == I_m, I_g1 == I_m/sqrt(2), I_g2 == I_m/sqrt(2) * exp(-1i*pi/sym(2))]
```

```
pobuda =
```

$$\left(I_{g0} = I_m \quad I_{g1} = \frac{\sqrt{2} I_m}{2} \quad I_{g2} = -\frac{\sqrt{2} I_m i}{2} \right)$$

```
frekvencije = [w0 == 0, w1 == 1/(2*sqrt(L*C)), w2 == 1/sqrt(L*C)]
```

```
frekvencije =
```

$$\left(w_0 = 0 \quad w_1 = \frac{1}{2\sqrt{C}\sqrt{L}} \quad w_2 = \frac{1}{\sqrt{C}\sqrt{L}} \right)$$

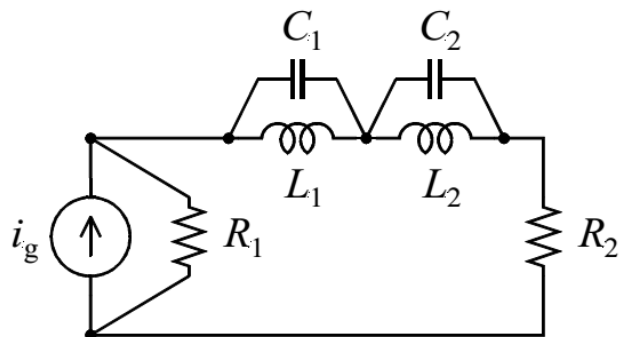

Određivanje kompleksne funkcije UR2

```
syms UR2(s) I_g
```

```
UR2(s) = (R1*I_g*R2)/(R1 + 1/(s*C1 + 1/(s*L1)) + 1/(s*C2 + 1/(s*L2)) + R2)
```

```
UR2(s) =
```

$$\frac{I_g R_1 R_2}{R_1 + R_2 + \frac{1}{C_1 s + \frac{1}{L_1 s}} + \frac{1}{C_2 s + \frac{1}{L_2 s}}}$$

```
syms UR2_jw(w)
```

```
UR2_jw(w) = simplify(subs(subs(UR2(s), lhs(zamene), rhs(zamene)), s, 1i*w))
```

```
UR2_jw(w) =
```

$$\frac{I_g R^2 (4 C^2 L^2 w^4 - 5 C L w^2 + 1)}{8 R C^2 L^2 w^4 - 6 C L^2 w^3 i - 10 R C L w^2 + 3 L w i + 2 R}$$

Хармоници, Временски домен

```
UR2_0 = simplify(subs(subs(subs(UR2_jw(w), [w I_g], [w0 I_g0]), lhs(frekvencije), rhs(frekvencije)), lhs(pobuda), rhs(pobuda)))
```

$$UR2_0 = \frac{I_m R}{2}$$

```
UR2_wg1 = simplify(subs(subs(subs(UR2_jw(w), [w I_g], [w1 I_g1]), lhs(frekvencije), rhs(frekvencije)), lhs(pobuda), rhs(pobuda)))
```

$$UR2_{wg1} = 0$$

```
UR2_wg2 = simplify(subs(subs(subs(UR2_jw(w), [w I_g], [w2 I_g2]), lhs(frekvencije), rhs(frekvencije)), lhs(pobuda), rhs(pobuda)))
```

$$UR2_{wg2} = 0$$

Времени домен за uR2

```
syms U0 Uwg1 Uwg2  
syms uR2(t)
```

```
uR2(t) = subs(UR2_0 + sqrt(2)*abs(UR2_wg1)*cos(w1*t + angle(UR2_wg1)) + sqrt(2)*abs(UR2_wg2)*cos(w2*t + angle(UR2_wg2)), lhs(frekvencije), rhs(frekvencije))
```

$$uR2(t) = \frac{I_m R}{2}$$

Одређивање комплексне функције UR1

syms Z(s)

Z(s) = simplify(1/(s * C1 + 1/(s*L1)) + 1/(s*C2 + 1/(s*L2)) + R2)

Z(s) =

$$R_2 + \frac{L_1 s}{C_1 L_1 s^2 + 1} + \frac{L_2 s}{C_2 L_2 s^2 + 1}$$

syms UR1(s)

UR1(s) = expand(subs(I_g*R1*Z(s)/(R1 + Z(s)), lhs(zamene), rhs(zamene)))

UR1(s) =

$$\frac{I_g R^2}{2R + \frac{Ls}{\sigma_1} + \sigma_2} + \frac{I_g L R s}{2R + \frac{Ls}{\sigma_1} + \sigma_2 + 2CLRs^2 + \frac{CL^2s^3}{\sigma_1} + \frac{2CL^2s^3}{\sigma_3}} + \frac{2I_g L R s}{2R + \frac{Ls}{\sigma_1} + \sigma_2 + 8CLRs^2 + \frac{4CL^2s^3}{\sigma_1} + \frac{8CL^2s^3}{\sigma_3}}$$

where

$$\sigma_1 = CLs^2 + 1$$

$$\sigma_2 = \frac{2Ls}{\sigma_3}$$

$$\sigma_3 = 4CLs^2 + 1$$

syms UR1_jw(w)

UR1_jw(w) = simplify(subs(UR1(s), s, 1i*w))

UR1_jw(w) =

$$\frac{(3Lw - 6CL^2w^3)\sigma_1 i - (8RC^2L^2w^4 - 10RCLw^2 + 2R)\sigma_1}{64C^4L^4R^2w^8 - 160C^3L^3R^2w^6 + 36C^2L^4w^6 + 132C^2L^2R^2w^4 - 36CL^3w^4 - 40CLR^2w^2 + 9L^2w^2 + 4R^2}$$

where

$$\sigma_1 = 4I_g C^2 L^2 R^2 w^4 - 6i I_g C L^2 R w^3 - 5I_g C L R^2 w^2 + 3i I_g L R w + I_g R^2$$

Хармоници, Временски домен

```
UR1_0 = simplify(subs(subs(subs(UR1_jw(w), [w I_g], [w0 I_g0]), lhs(frekvencije), rhs(frekvencije)), lhs(pobuda), rhs(pobuda)))
```

$$UR1_0 = \frac{I_m R}{2}$$

```
UR1_wg1 = simplify(subs(subs(subs(UR1_jw(w), [w I_g], [w1 I_g1]), lhs(pobuda), rhs(pobuda)), lhs(frekvencije), rhs(frekvencije)))
```

$$UR1_wg1 = \frac{\sqrt{2} I_m R}{2}$$

```
UR1_wg2 = simplify(subs(subs(subs(UR1_jw(w), [w I_g], [w2 I_g2]), lhs(pobuda), rhs(pobuda)), lhs(frekvencije), rhs(frekvencije)))
```

$$UR1_wg2 = -\frac{\sqrt{2} I_m R i}{2}$$

Временски домен за uR1

```
syms uR1(t)
uR1(t) = subs(UR1_0 + sqrt(sym(2)) * abs(UR1_wg1) * cos(w1 * t + angle(UR1_wg1)) + sqrt(sym(2)) * abs(UR1_wg2) * cos(w2 * t + angle(UR1_wg2)), lhs(frekvencije), rhs(frekvencije))
```

$$uR1(t) = \frac{I_m R}{2} + I_m R \cos\left(\frac{t}{2\sqrt{C}\sqrt{L}}\right) + I_m R \cos\left(\frac{\pi}{2} - \frac{t}{\sqrt{C}\sqrt{L}}\right)$$

```
simplify(uR1(t))
```

$$ans = \frac{I_m R \left(2 \cos\left(\frac{t}{2\sqrt{C}\sqrt{L}}\right) + 2 \sin\left(\frac{t}{\sqrt{C}\sqrt{L}}\right) + 1\right)}{2}$$

MATLAB: Symbolic Toolbox

KHN active filter

Kerwin-Huelsman-Newcomb, state-variable biquad, UAF42

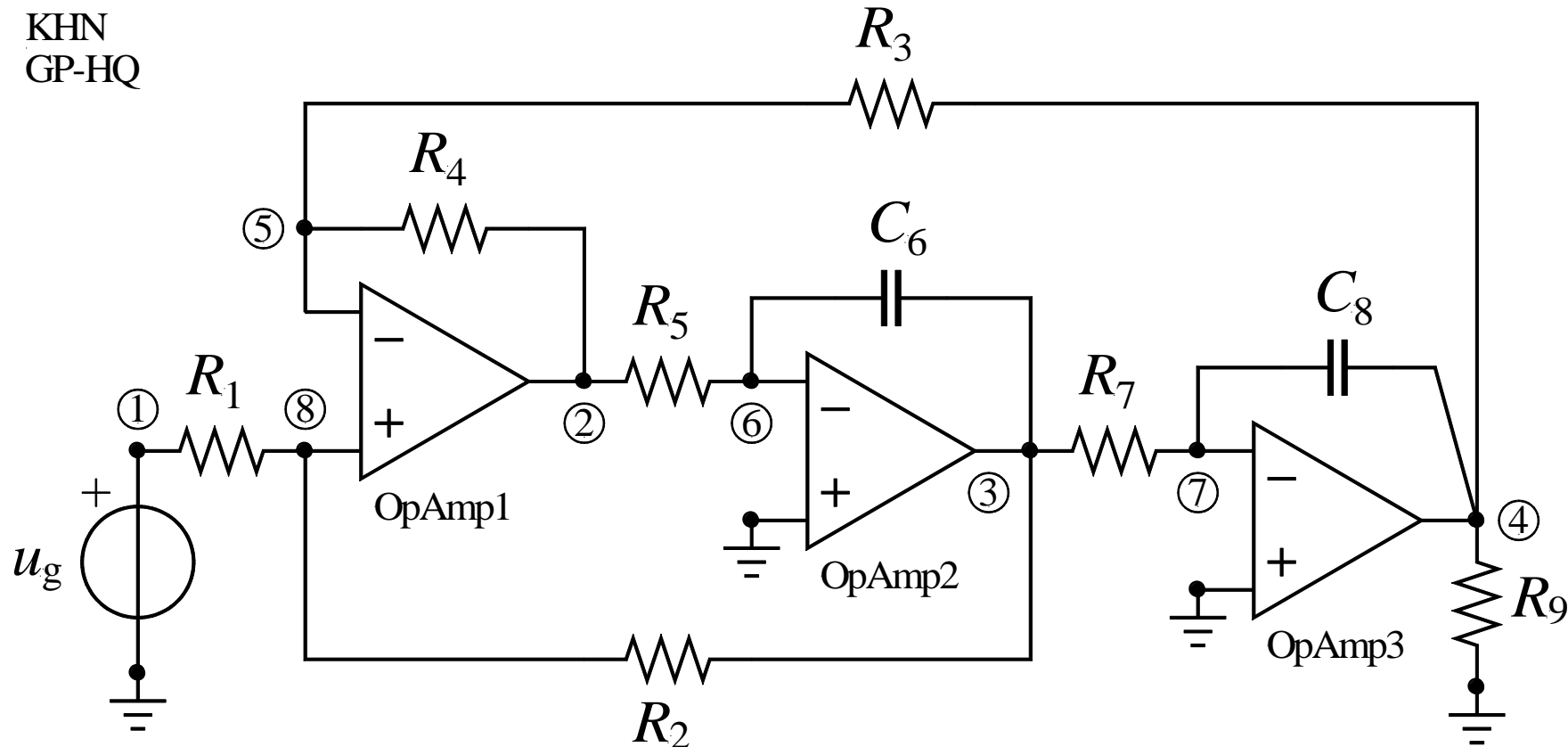

Kerwin-Huelsman-Newcomb, state-variable biquad, UAF42

KHN active filter

$$R_1 = R_3 = R_5 = R_7 = R_9 = R = 1\text{k}\Omega$$

$$C_6 = C_8 = C = 1\mu\text{F}$$

KHN
GP-HQ

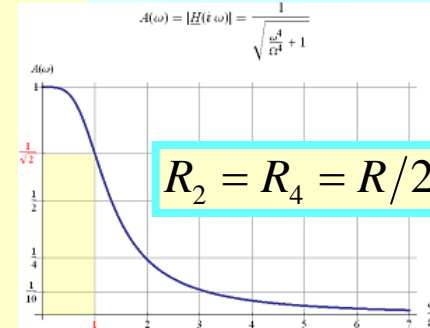
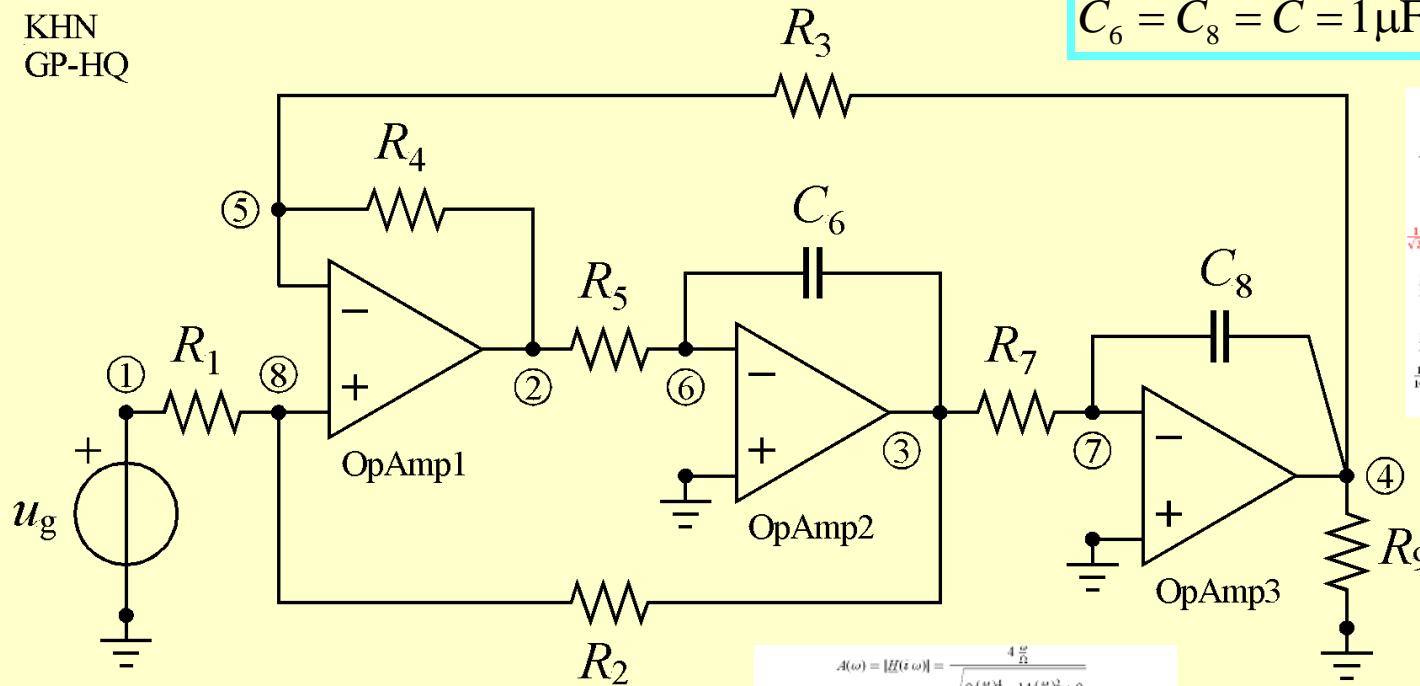

$$\underline{H}(s) = \frac{V_4(s)}{U_g(s)}$$

LowPass, LP

HighPass, HP

$$\underline{H}(s) = \frac{V_2(s)}{U_g(s)}$$

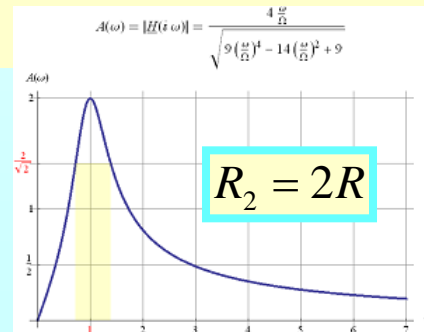
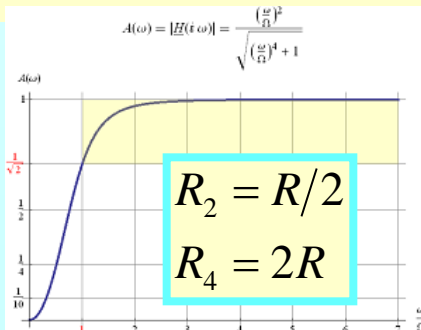

$$\underline{H}(s) = \frac{V_3(s)}{U_g(s)}$$

BandPass, BP

УЛАЗ – ИЗЛАЗ КОЛА (СИСТЕМА) Филтар пропусник ниских учестаности

Input Perturbation

Output Measurement

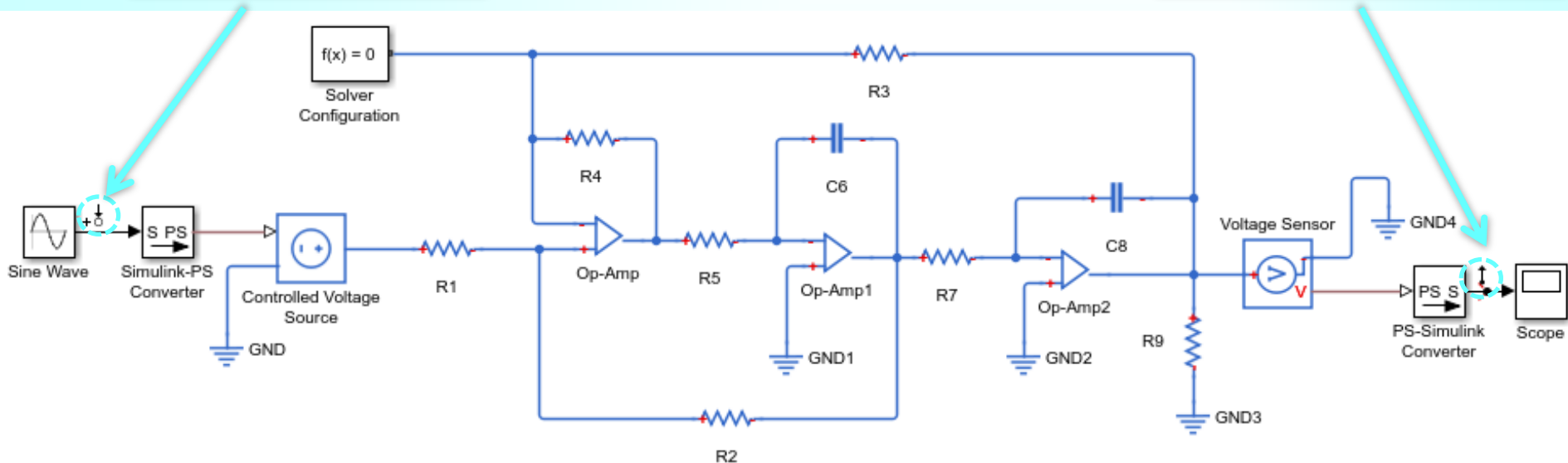

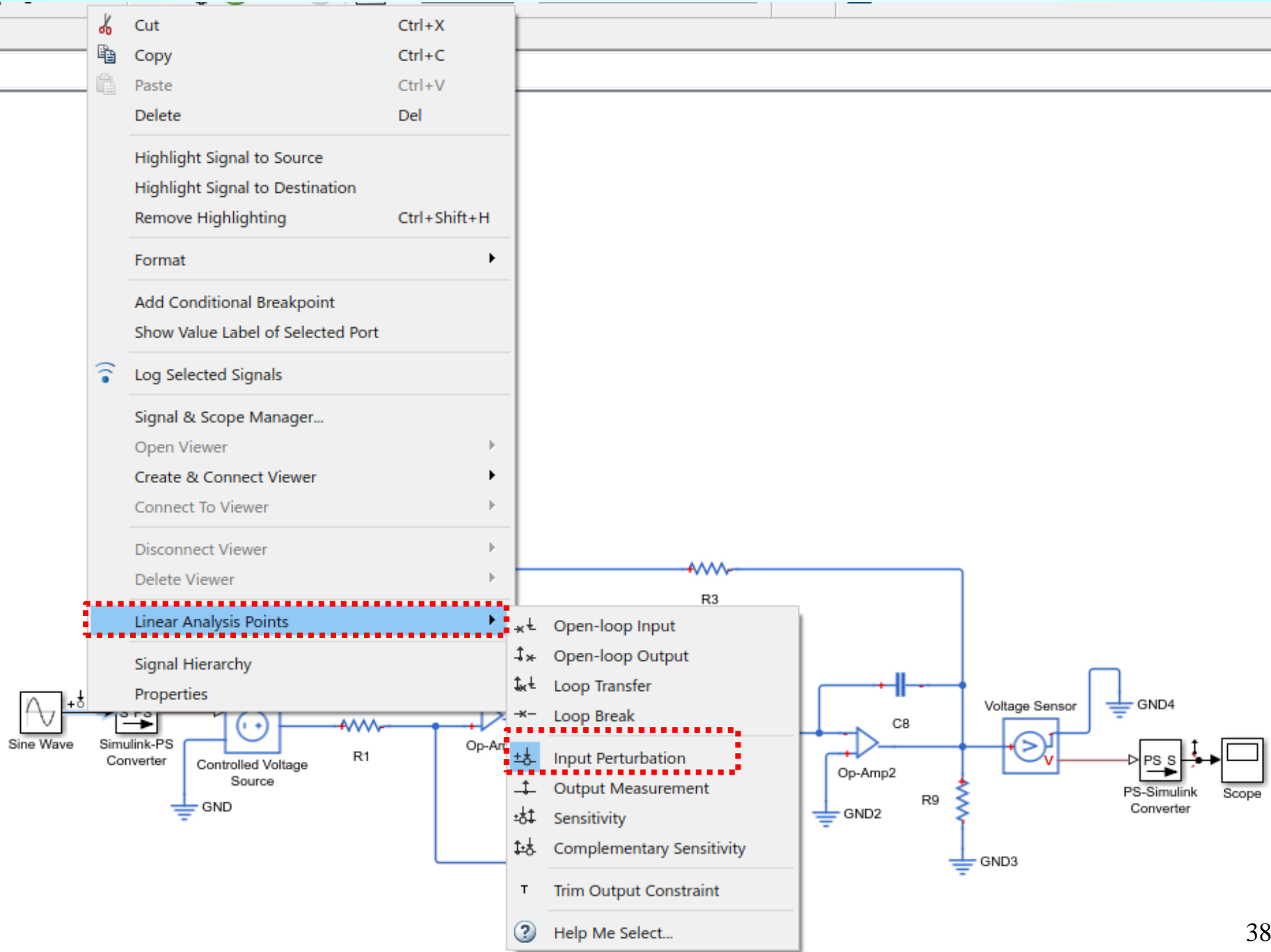

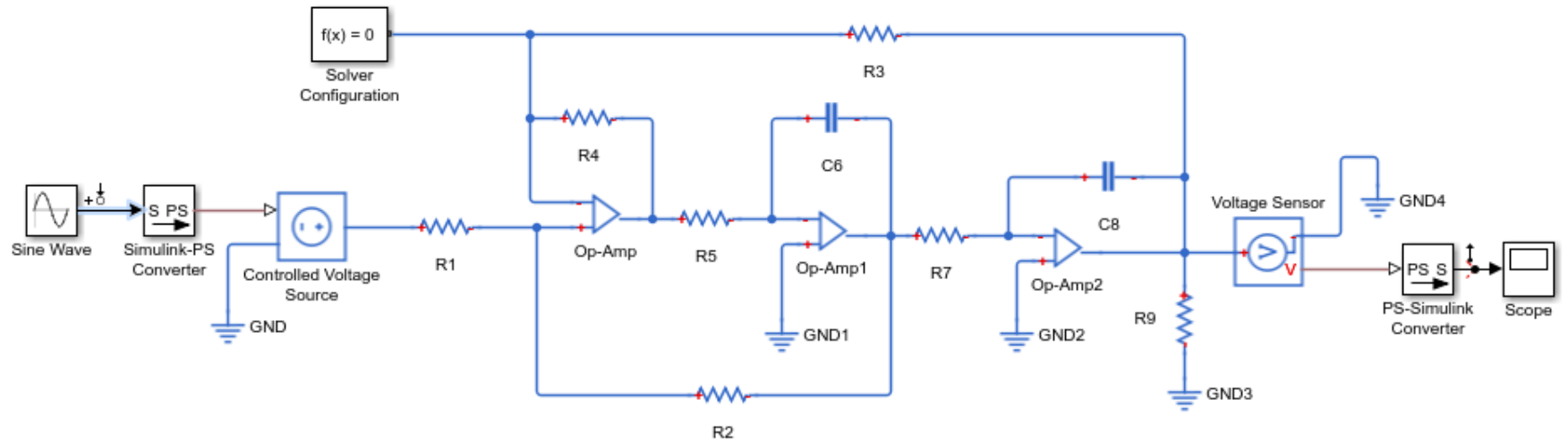
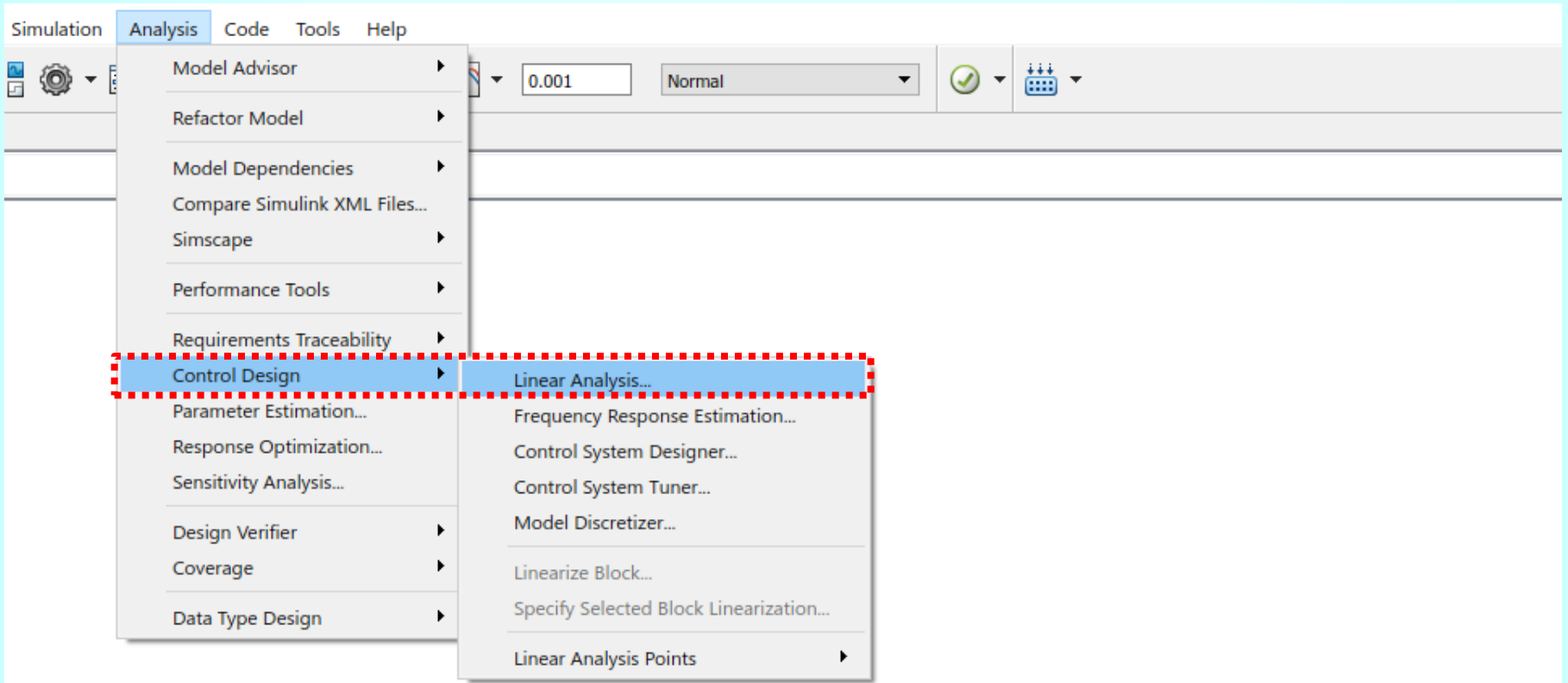

LINEAR ANALYSIS ESTIMATION PLOTS AND RESULTS VIEW

Analysis I/Os: Model I/Os
 Operating Point: Model Initial Condition
 Parameter Variations: None

Result Viewer
 Diagnostic Viewer
 More Options

Bode Plot 1 Step Bode Impulse Nyquist

FILE SETUP OPTIONS LINEARIZE

Data Browser

Search workspace variables

MATLAB Workspace

Name	Value
ans	1x1 mupad

Linear Analysis Workspace

Name	Value
linsys1	1x1 ss

Variable Preview

Филтар пропусник ниских учестаности

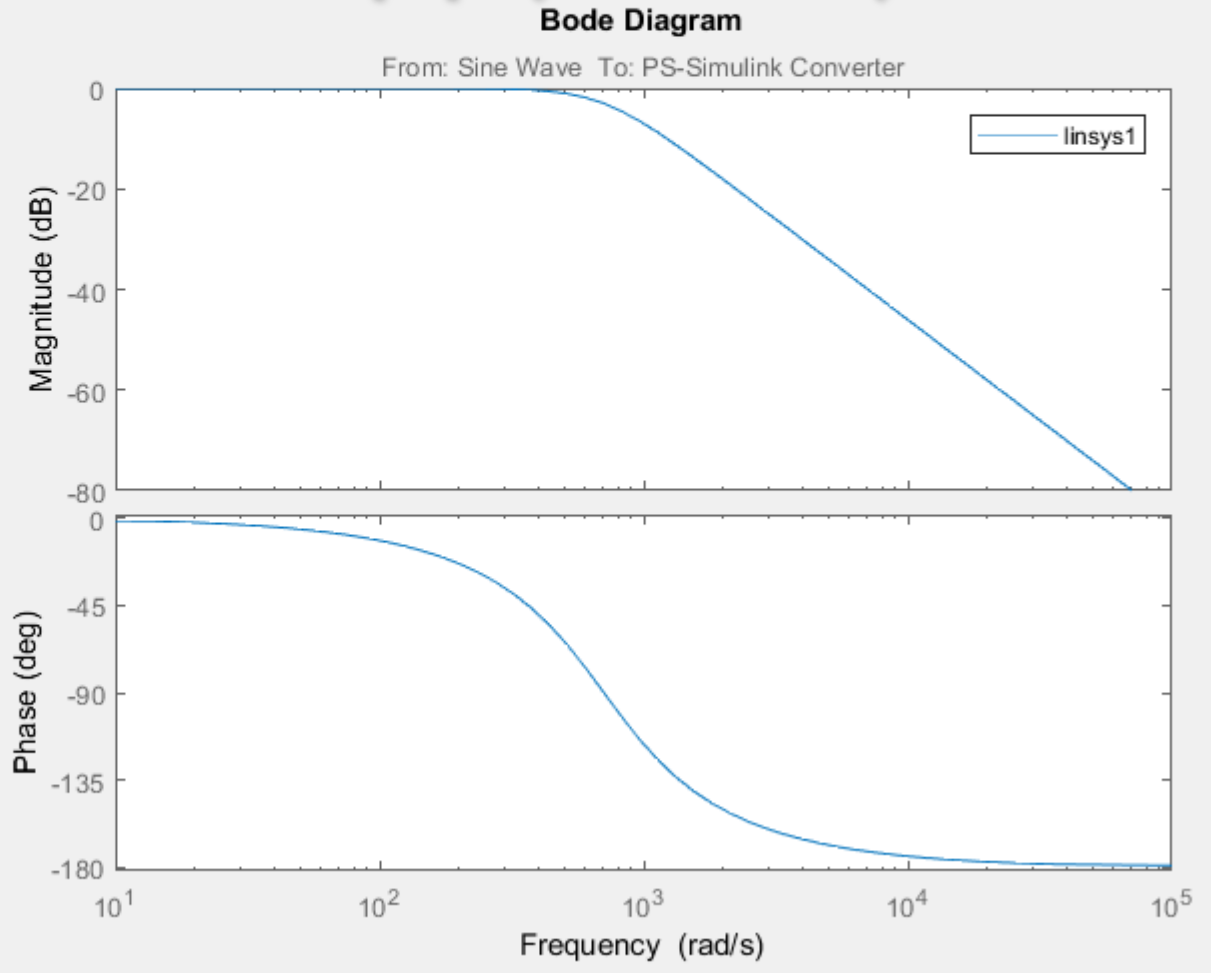

Филтар пропусник опсега учестаности

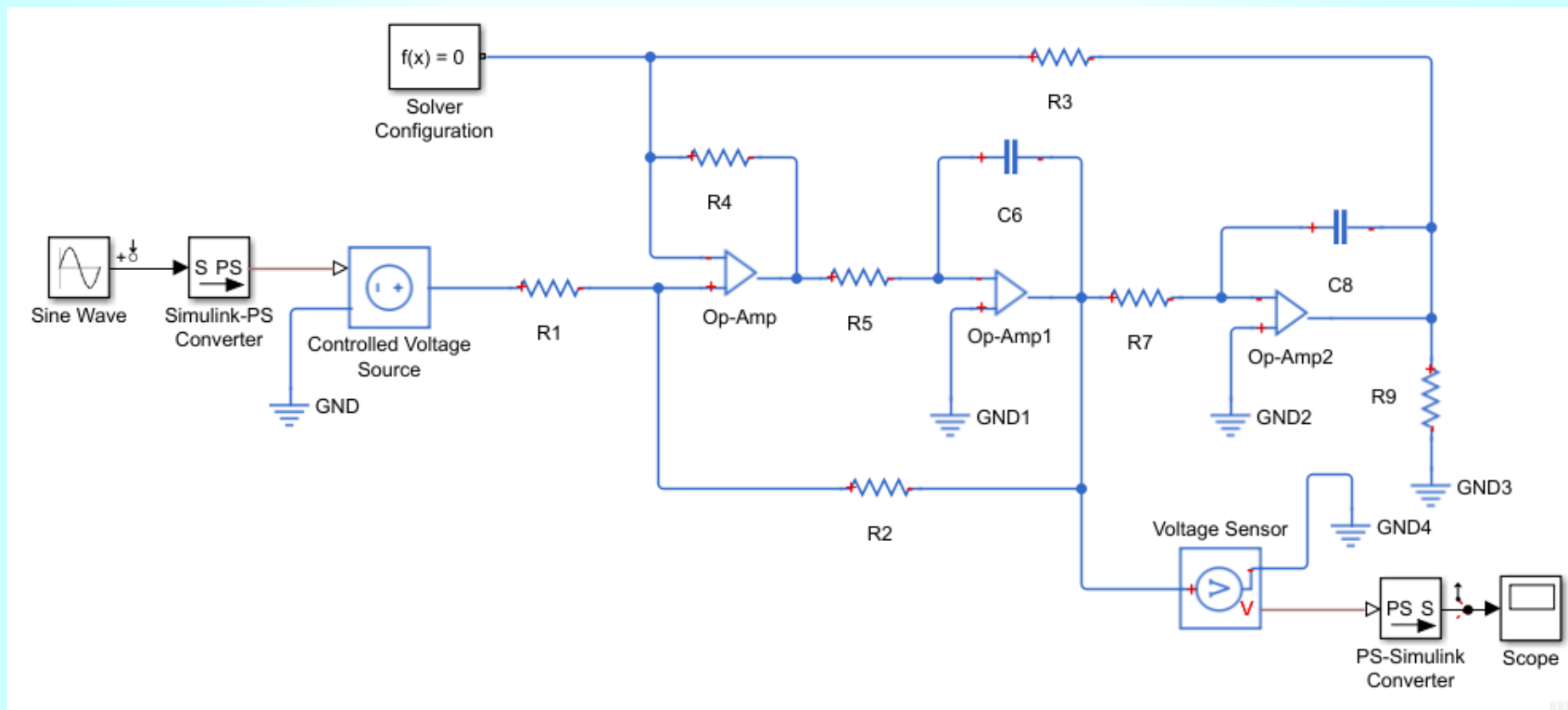

LINEAR ANALYSIS ESTIMATION PLOTS AND RESULTS BODE PLOT 1 VIEW

Analysis I/Os: Model I/Os
 Operating Point: Model Initial Condition
 Parameter Variations: None

Result Viewer
 Diagnostic Viewer
 More Options

Bode Plot 1 Step Bode Impulse Nyquist

FILE SETUP OPTIONS LINEARIZE

Data Browser

Search workspace variables

MATLAB Workspace

Name	Value
ans	1x1 mupad

Linear Analysis Workspace

Name	Value
linsys1	1x1 ss

Variable Preview

Филтар пропусник опсега учестаности
Bode Diagram

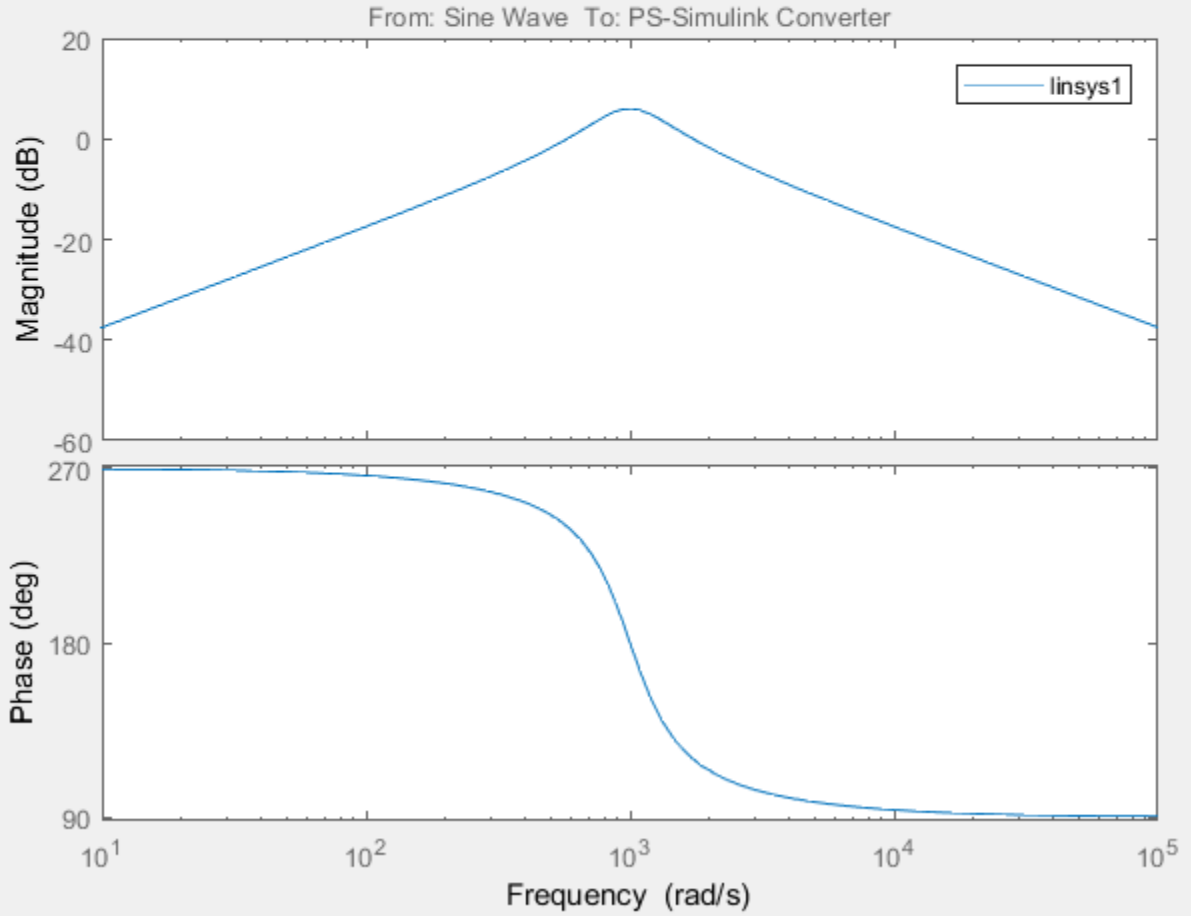

Филтар пропусник високих учестаности

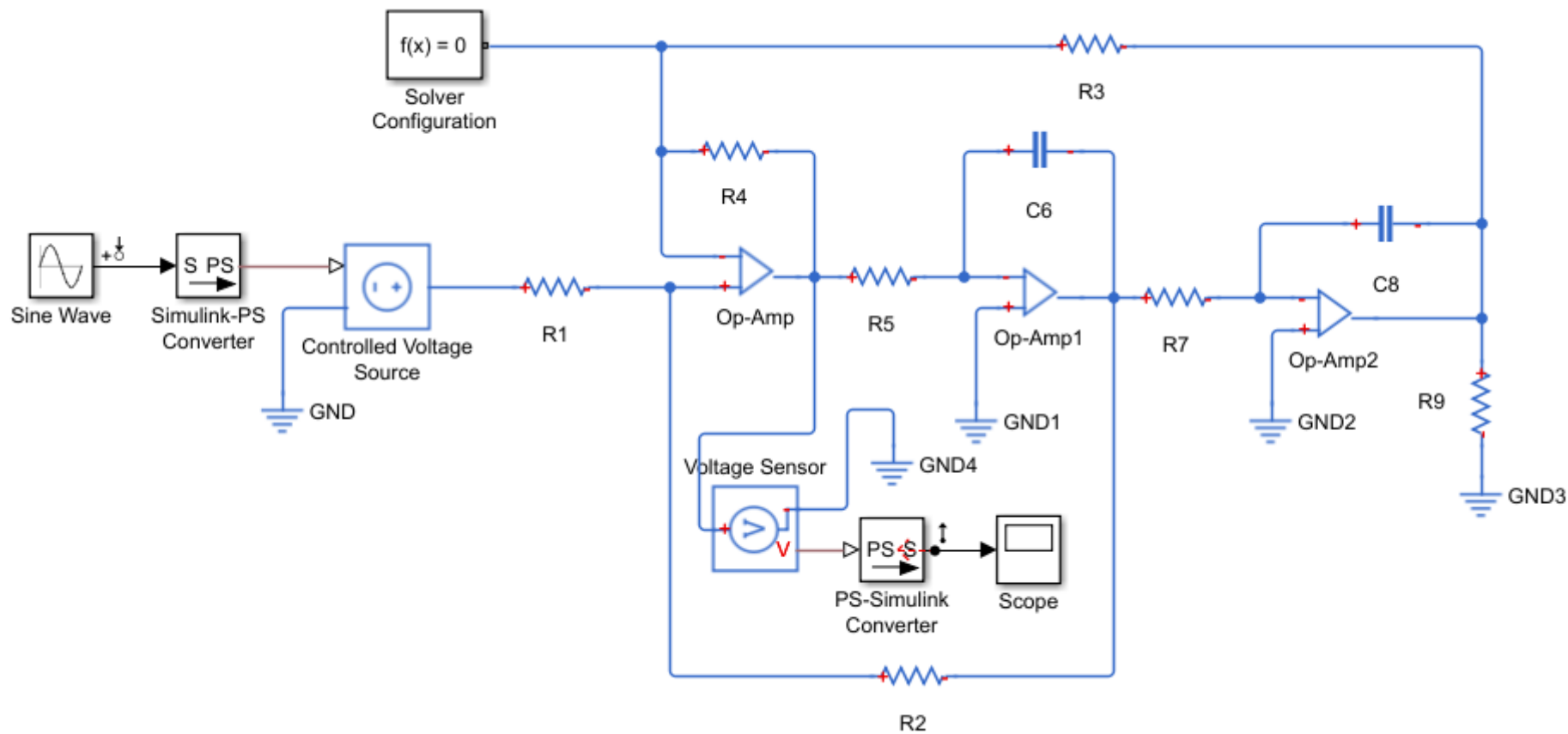

LINEAR ANALYSIS ESTIMATION PLOTS AND RESULTS BODE PLOT 1 VIEW

Analysis I/Os: Model I/Os
 Operating Point: Model Initial Condition
 Parameter Variations: None

Result Viewer
 Diagnostic Viewer
 More Options

Bode Plot 1 Step Bode Impulse Nyquist

FILE SETUP OPTIONS LINEARIZE

Data Browser

Search workspace variables

MATLAB Workspace

Name	Value
ans	1x1 mupad

Linear Analysis Workspace

Name	Value
linsys1	1x1 ss

Variable Preview

Филтар пропусник високих учестаности

Bode Diagram

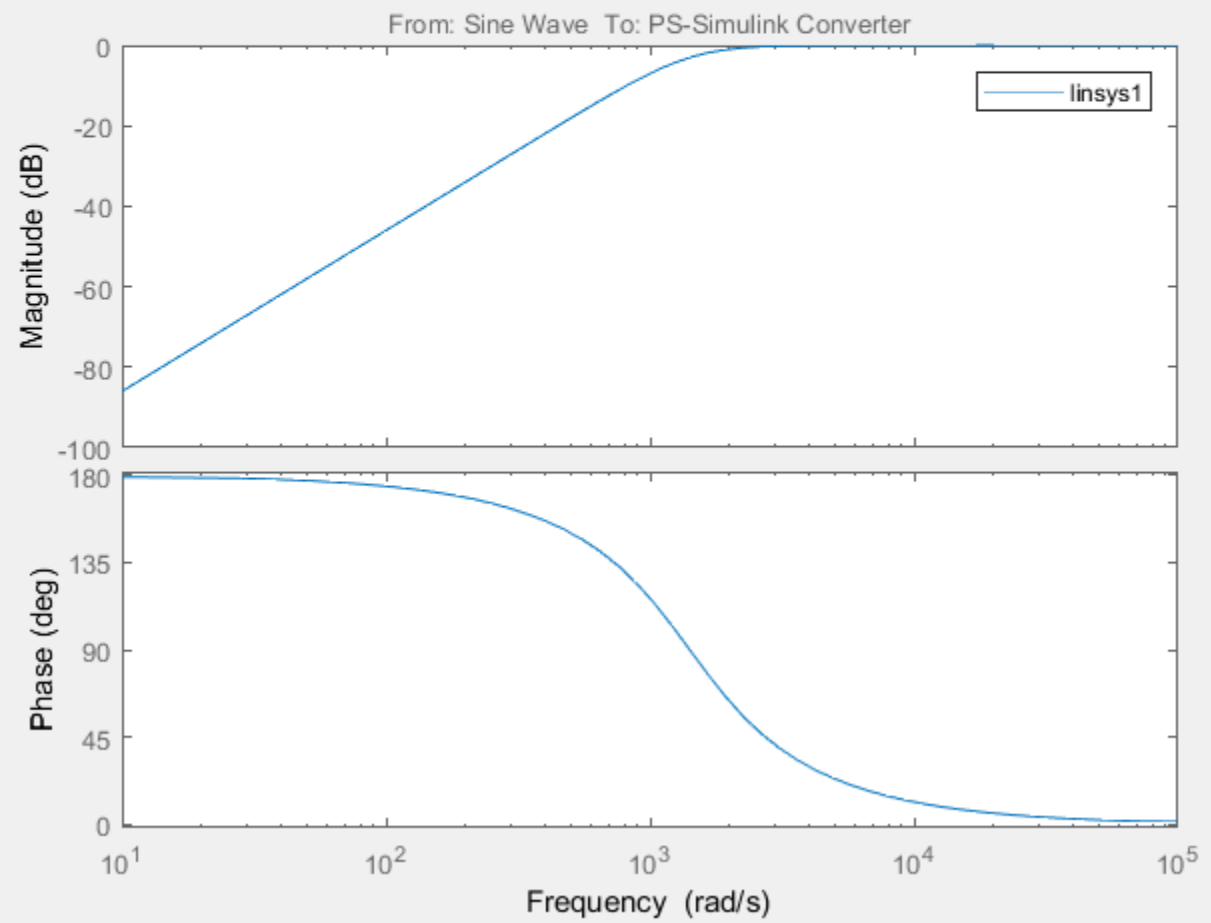

KHN active filter

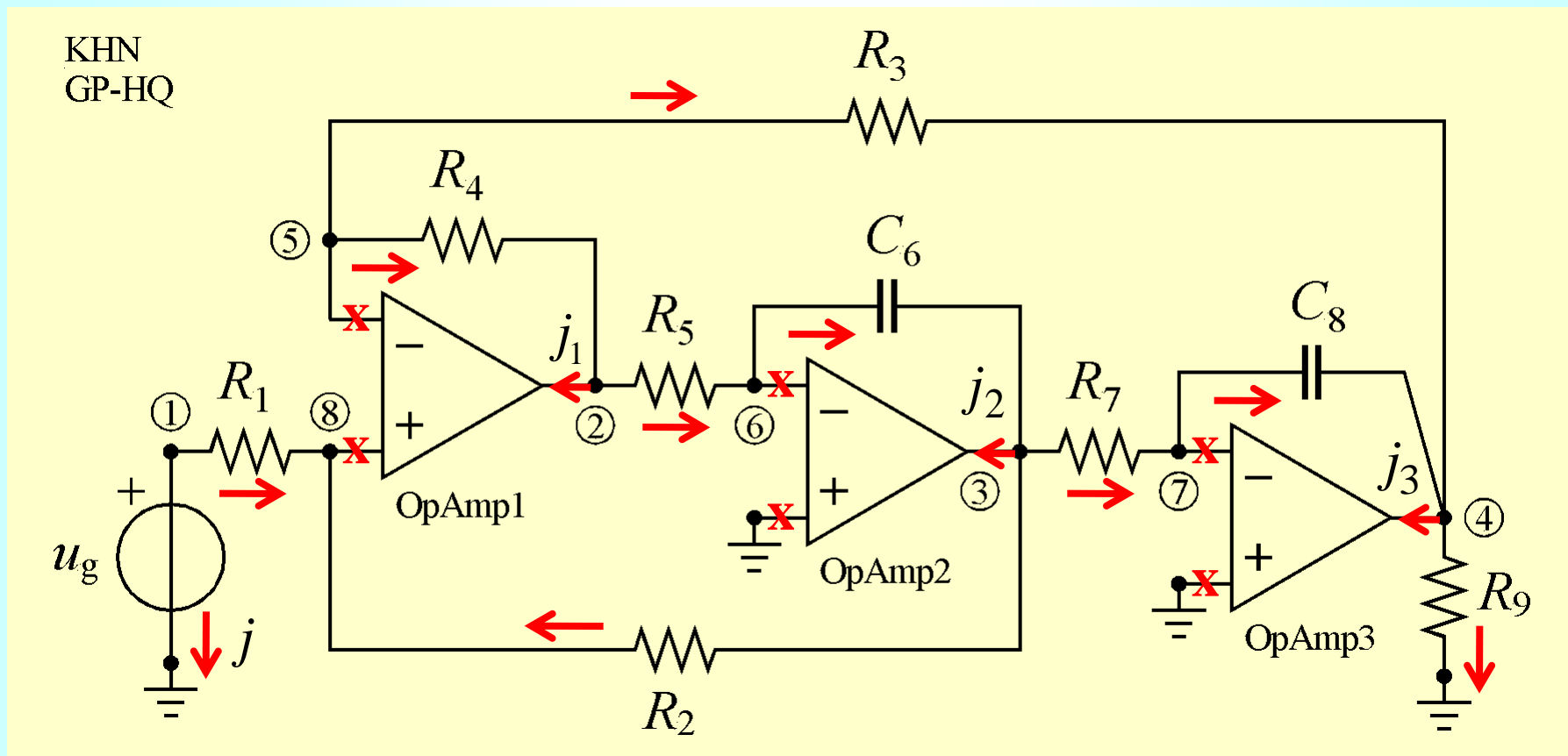

$$H_{\text{LowPass}}(s) = \frac{V_4(s)}{V_1(s)} = ?$$

$$H_{\text{BandPass}}(s) = \frac{V_3(s)}{V_1(s)} = ?$$

$$H_{\text{HighPass}}(s) = \frac{V_2(s)}{V_1(s)} = ?$$

KHN active filter

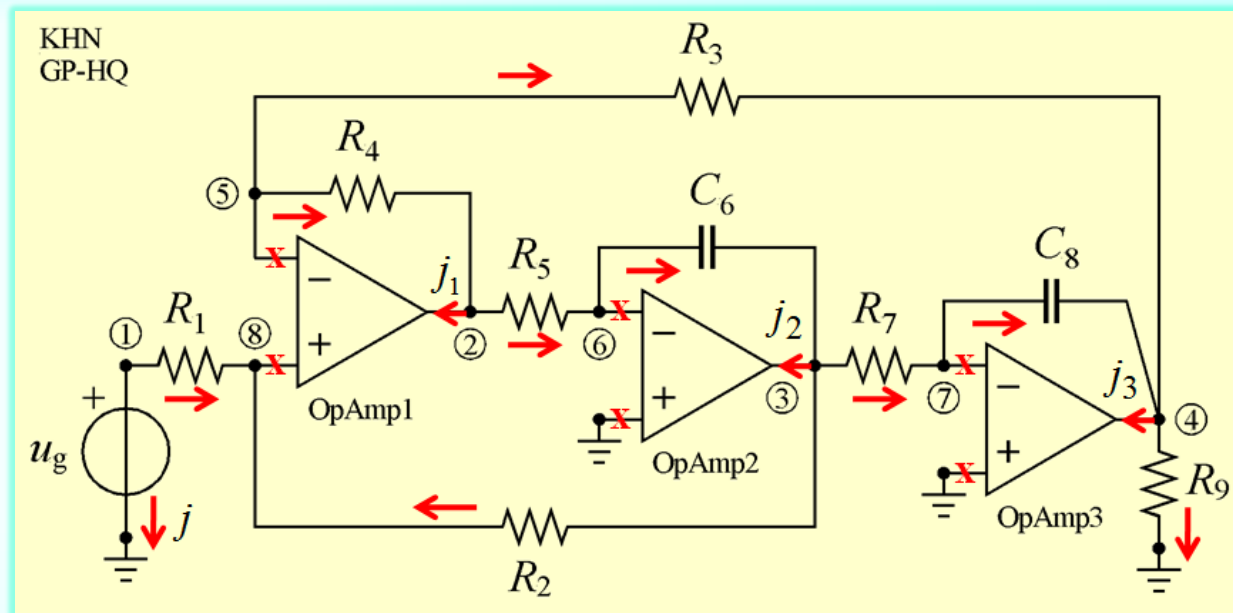

$$(1) \underline{J} + (\underline{V}_1 - \underline{V}_8)/R_1 = 0$$

$$(2) \underline{J}_1 + (\underline{V}_2 - \underline{V}_6)/R_5 - (\underline{V}_5 - \underline{V}_2)/R_4 = 0$$

$$(3) \underline{J}_2 + (\underline{V}_3 - \underline{V}_8)/R_2 + (\underline{V}_3 - \underline{V}_7)/R_7 - sC_6(\underline{V}_6 - \underline{V}_3) = 0$$

$$(4) \underline{J}_3 - (\underline{V}_5 - \underline{V}_4)/R_3 + \underline{V}_4/R_9 - sC_8(\underline{V}_7 - \underline{V}_4) = 0$$

$$(5) (\underline{V}_5 - \underline{V}_2)/R_4 + (\underline{V}_5 - \underline{V}_4)/R_3 = 0$$

$$(6) -(\underline{V}_2 - \underline{V}_6)/R_5 + sC_6(\underline{V}_6 - \underline{V}_3) = 0$$

$$(7) -(\underline{V}_3 - \underline{V}_7)/R_7 + sC_8(\underline{V}_7 - \underline{V}_4) = 0$$

$$(8) -(\underline{V}_1 - \underline{V}_8)/R_1 - (\underline{V}_3 - \underline{V}_8)/R_2 = 0$$

$$\underline{V}_5 = \underline{V}_8$$

$$\underline{V}_6 = 0$$

$$\underline{V}_7 = 0$$

$$\underline{V}_1 = \underline{U}_g$$

```
clear variables
close all

syms C C6 C8 R R1 R2 R3 R4 R5 R7 Ug s w
assume(0<R1 & 0<R2 & 0<R3 & 0<R4 & 0<R5 & 0<C6 & 0<R7 & 0<C8 & 0<R & 0<C & 0<Ug & s~= 0 & 0<w)
```

Zamene

```
zamena_LowPass = [R1 == R, R2 == R/2, R3 == R, R4 == R/2, R5 == R, C6 == C, R7 == R, C8 == C]
```

```
zamena_LowPass =
```

$$\left(R_1 = R \quad R_2 = \frac{R}{2} \quad R_3 = R \quad R_4 = \frac{R}{2} \quad R_5 = R \quad C_6 = C \quad R_7 = R \quad C_8 = C \right)$$

```
zamena_BandPass = [R1 == R, R2 == 2 * R, R3 == R, R4 == R, R5 == R, C6 == C, R7 == R, C8 == C]
```

$$\left(R_1 = R \quad R_2 = 2R \quad R_3 = R \quad R_4 = R \quad R_5 = R \quad C_6 = C \quad R_7 = R \quad C_8 = C \right)$$

```
zamena_HighPass = [R1 == R, R2 == R/2, R3 == R, R4 == 2 * R, R5 == R, C6 == C, R7 == R, C8 == C]
```

```
zamena_HighPass =
```

$$\left(R_1 = R \quad R_2 = \frac{R}{2} \quad R_3 = R \quad R_4 = 2R \quad R_5 = R \quad C_6 = C \quad R_7 = R \quad C_8 = C \right)$$

Vrednosti

```
vrednosti = [R == 1, C == 1]
```

```
vrednosti = (R = 1 C = 1)
```

```
w0 = 1/(R*C)
```

```
w0 =
    1
   C R
```

Jednacine

```
syms J J1 J2 J3 R9 V1 V2 V3 V4 V5 V6 V7 V8 v4
jednacine = [J + (V1 - V8)/R1 == 0, ...
             J1 + (V2 - V6)/R5 - (V5 - V2)/R4 == 0, ...
             J2 + (V3 - V8)/R2 + (V3 - V7)/R7 - s*C6*(V6 - V3) == 0, ...
             J3 - (V5 - V4)/R3 + v4/R9 - s * C8 * (V7 - V4) == 0, ...
             (V5 - V2)/R4 + (V5 - V4)/R3 == 0, ...
             -((V2 - V6)/R5) + s * C6 * (V6 - V3) == 0, ...
             -((V3 - V7)/R7) + s * C8 * (V7 - V4) == 0, ...
             -((V1 - V8)/R1) - (V3 - V8)/R2 == 0, ...
             V5 == V8, V6 == 0, V7 == 0, V1 == Ug]
```

jednacine =

$$\left(J + \frac{V_1 - V_8}{R_1} = 0 \quad J_1 + \frac{V_2 - V_5}{R_4} + \frac{V_2 - V_6}{R_5} = 0 \quad J_2 + \frac{V_3 - V_8}{R_2} + \frac{V_3 - V_7}{R_7} + \sigma_2 = 0 \quad J_3 + \frac{V_4 - V_5}{R_3} - \frac{v_4}{R_9} + s \cdot C_8 \cdot (V_7 - V_4) = 0 \right.$$

where

$$\sigma_1 = C_8 s (V_4 - V_7)$$

$$\sigma_2 = C_6 s (V_3 - V_6)$$

Promenljive

```
promenljive = [V1, V2, V3, V4, V5, V6, V7, V8, J, J1, J2, J3]
```

```
promenljive = (V1 V2 V3 V4 V5 V6 V7 V8 J J1 J2 J3)
```

```
odziv = solve(jednacine, promenljive)
```

Low Pass odziv

```
syms V4_1(s) H_LowPass(s) Hjw_LowPass(w)
```

```
V4_1(s) = subs(odziv.V4, lhs(zamena_LowPass), rhs(zamena_LowPass))
```

$$V4_1(s) = \frac{3 R^2 U_g}{4 \left(\frac{3 C^2 R^4 s^2}{2} + \frac{3 C R^3 s}{2} + \frac{3 R^2}{4} \right)}$$

```
H_LowPass(s) = simplify(V4_1(s)/Ug)
```

$$H_LowPass(s) = \frac{1}{2 C^2 R^2 s^2 + 2 C R s + 1}$$

```
Hjw_LowPass(w) = subs(H_LowPass(s), s, 1i*w)
```

$$Hjw_LowPass(w) = \frac{1}{-2 C^2 R^2 w^2 + 2 C R w i + 1}$$

```
Aw_LowPass(w) = simplify(abs(Hjw_LowPass(w)))
```

$$Aw_LowPass(w) = \frac{1}{|-2 C^2 R^2 w^2 + 2 C R w i + 1|}$$

```
phi_LowPass(w) = simplify(angle(Hjw_LowPass(w)))
```

$$phi_LowPass(w) = \text{angle} \left(\frac{1}{-2 C^2 R^2 w^2 + 2 C R w i + 1} \right)$$

Band Pass odziv

```
syms V3_1(s) H_BandPass(s) Hjw_BandPass(w)
```

```
V3_1(s) = subs(odziv.V3, lhs(zamena_BandPass), rhs(zamena_BandPass))
```

$$V3_1(s) = -\frac{4 C R^3 U_g s}{3 C^2 R^4 s^2 + 2 C R^3 s + 3 R^2}$$

```
H_BandPass(s) = simplify(V3_1(s)/Ug)
```

$$H_BandPass(s) = -\frac{4 C R s}{3 C^2 R^2 s^2 + 2 C R s + 3}$$

```
Hjw_BandPass(w) = subs(H_BandPass(s), s, 1i*w)
```

$$Hjw_BandPass(w) = -\frac{4 C R w i}{-3 C^2 R^2 w^2 + 2 C R w i + 3}$$

```
Aw_BandPass(w) = simplify(abs(Hjw_BandPass(w)))
```

$$Aw_BandPass(w) = \frac{4 C R |w|}{|-3 C^2 R^2 w^2 + 2 C R w i + 3|}$$

```
phi_BandPass(w) = simplify(angle(Hjw_BandPass(w)))
```

$$phi_BandPass(w) = \text{angle} \left(-\frac{w i}{-3 C^2 R^2 w^2 + 2 C R w i + 3} \right)$$

High Pass odziv

```
syms V2_1(s) H_HighPass(s)
V2_1(s) = subs(odziv.V2, lhs(zamena_HighPass), rhs(zamena_HighPass))
```

$$V2_1(s) = \frac{3 C^2 R^4 U_g s^2}{2 \left(\frac{3 C^2 R^4 s^2}{2} + 3 C R^3 s + 3 R^2 \right)}$$

```
H_HighPass(s) = simplify(V2_1(s)/Ug)
```

$$H_HighPass(s) = \frac{C^2 R^2 s^2}{C^2 R^2 s^2 + 2 C R s + 2}$$

```
Hjw_HighPass(w) = subs(H_HighPass(s), s, 1i*w)
```

$$Hjw_HighPass(w) = \frac{C^2 R^2 w^2}{-C^2 R^2 w^2 + 2 C R w i + 2}$$

```
Aw_HighPass(w) = simplify(abs(Hjw_HighPass(w)))
```

$$Aw_HighPass(w) = \frac{C^2 R^2 |w|^2}{|-C^2 R^2 w^2 + 2 C R w i + 2|}$$

```
phi_HighPass(w) = simplify(angle(Hjw_HighPass(w)))
```

$$\phi_HighPass(w) = \text{angle} \left(-\frac{w^2}{-C^2 R^2 w^2 + 2 C R w i + 2} \right)$$

Crtanje grafika frekvencijskih karakteristika

```
figure
yyaxis left
fplot(subs(Aw_LowPass(w), lhs(vrednosti), rhs(vrednosti)), [0, 5])
ylabel('Low Pass, A(w)')

yyaxis right
fplot(w, subs(phi_LowPass(w), lhs(vrednosti), rhs(vrednosti)), [0, 5])
ylabel('\phi(w) [rad]')

xlabel('w')
grid on
```

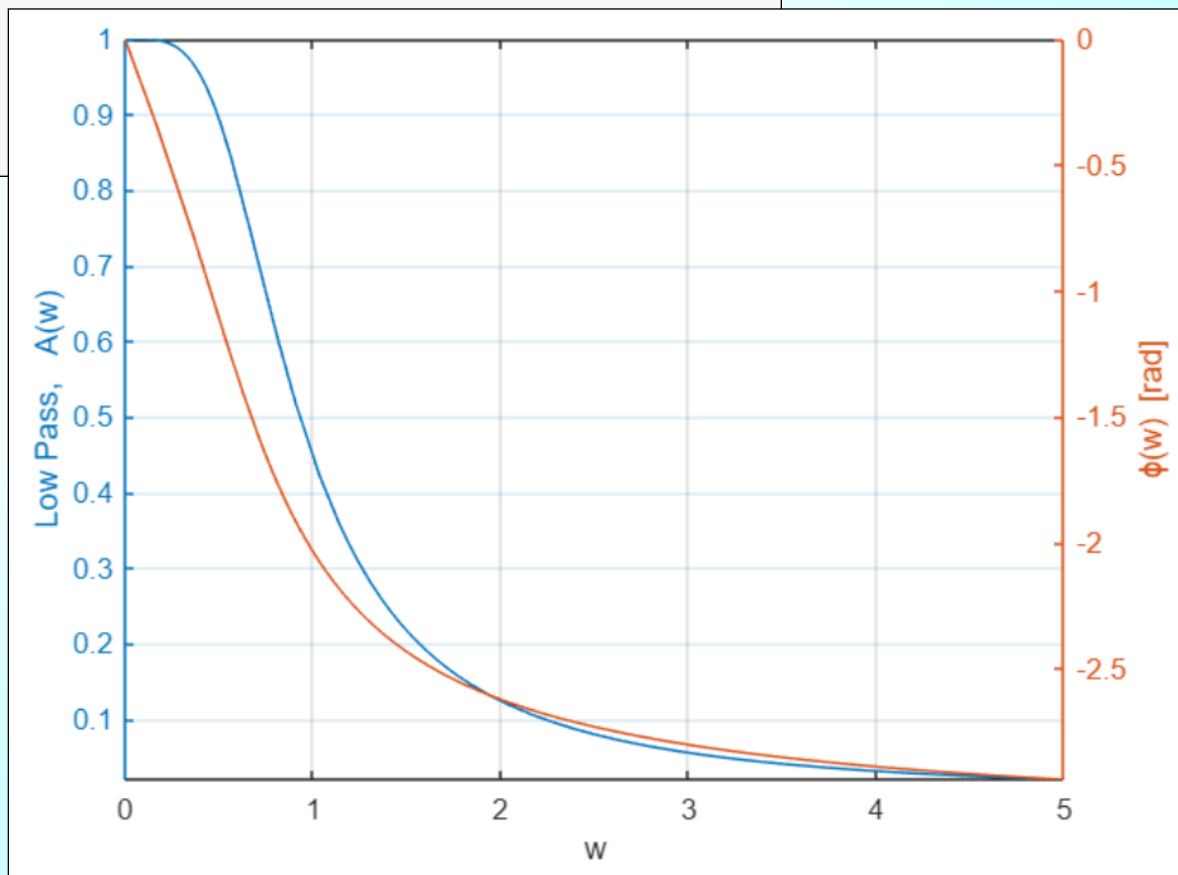

```
figure
yyaxis left
fplot(subs(Aw_BandPass(w), lhs(vrednosti), rhs(vrednosti)), [0, 5])
ylabel('Low Pass, A(w)')

yyaxis right
fplot(w, subs(phi_BandPass(w), lhs(vrednosti), rhs(vrednosti)), [0, 5])
ylabel('\phi(w) [rad]')

xlabel('w')
grid on
```

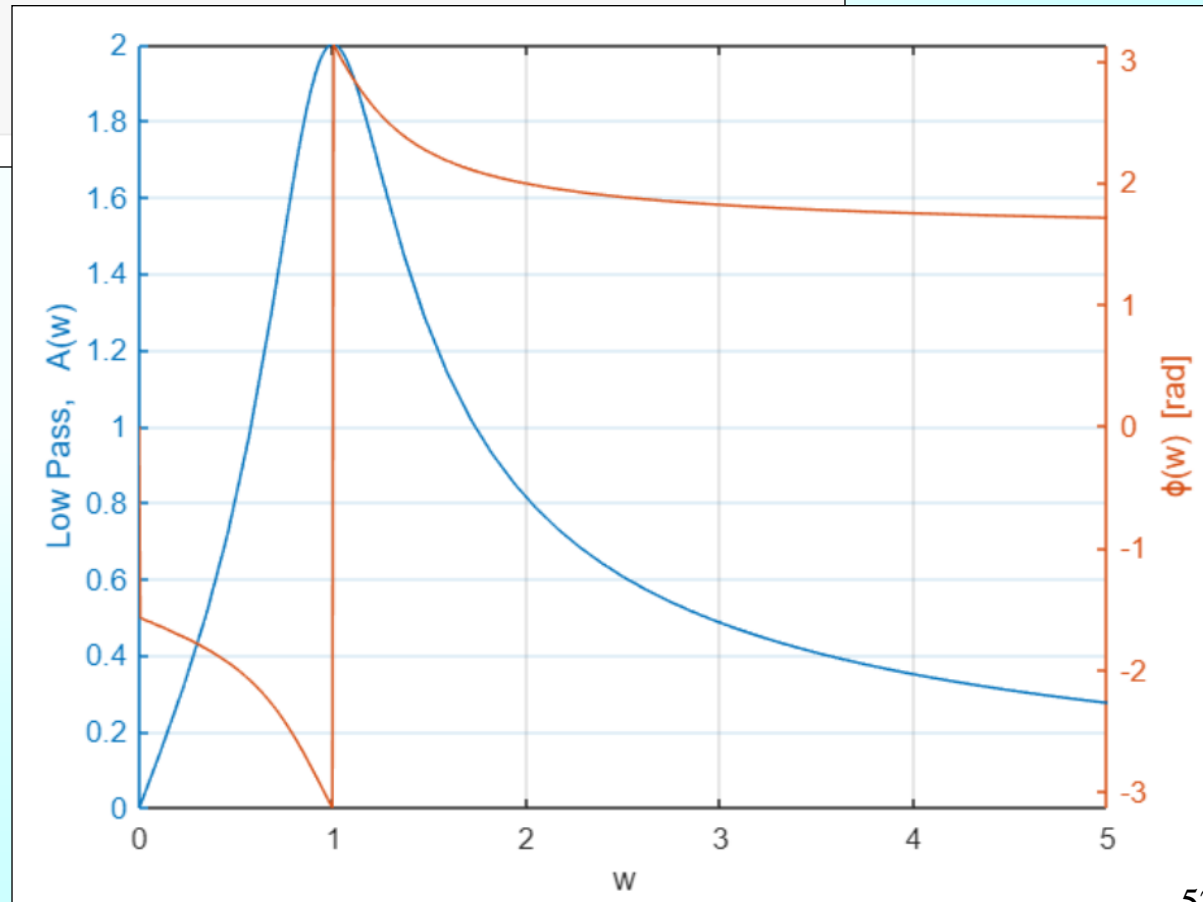

```
figure
yyaxis left
fplot(subs(Aw_HighPass(w), lhs(vrednosti), rhs(vrednosti)), [0, 5])
ylabel('Low Pass, A(w)')

yyaxis right
fplot(w, subs(phi_HighPass(w), lhs(vrednosti), rhs(vrednosti)), [0,5])
ylabel('\phi(w) [rad]')

xlabel('w')
grid on
```

